



User Manual

# 10/100M Print Server

Model No.: SP755D, SP756

<http://www.micronet.info>

## COPYRIGHT

Copyright ©2006/2007 by this company. All rights reserved. No part of this publication may be reproduced, transmitted, transcribed, stored in a retrieval system, or translated into any language or computer language, in any form or by any means, electronic, mechanical, magnetic, optical, chemical, manual or otherwise, without the prior written permission of this company.

## FCC COMPLIANCE STATEMENT

This device complies with Part 15 of the FCC Rules. Operation is subject to the following two conditions: (1) this device may not cause harmful interference, and (2) this device must accept any interference received, including interference that may cause undesired operation.

Any changes or modifications not expressly approved by the party responsible for compliance could void the authority to operate equipment.

## DISCLAIMER

This company makes no representations or warranties, either expressed or implied, with respect to the contents hereof and specifically disclaims any warranties, merchantability or fitness for any particular purpose. Any software described in this manual is sold or licensed "as is". Should the programs prove defective following their purchase, the buyer (and not this company, its distributor, or its dealer) assumes the entire cost of all necessary servicing, repair, and any incidental or consequential damages resulting from any defect in the software. Further, this company reserves the right to revise this publication and to make changes from time to time in the contents hereof without obligation to notify any person of such revision or changes.



# Contents

<b>1. INTRODUCTION .....</b>	<b>1</b>
1.1 Product Introduction .....	1
Product Package.....	1
1.2 Network Printing Architecture.....	2
1.2.1 Print Server Network Functions .....	3
1.2.2 Network Printing Functions for Clients.....	4
1.2.3 Network Printing Functions for Network Server.....	6
1.3 Network Printing Environment.....	7
1.4 Contents of the User's Manual .....	9
1.5 Firmware & Printing Function .....	10
<b>2. HARDWARE INSTALLATION .....</b>	<b>11</b>
<b>3. PEER-TO-PEER NETWORK .....</b>	<b>12</b>
3.1 System Architecture .....	12
3.2 Administrator Installation and Setup .....	13
3.3 Administrator Utilities.....	20
3.4 Client Installation and Setup.....	21
3.5.1 to add network ports of print servers manually.....	24
3.5 Client Utilities.....	26
3.5.1 Network Ports Quick Setup.....	27
3.5.2 Remote Ports (Utility).....	29
3.6 Windows Add Printer Procedure .....	31
<b>4. WINDOWS NT/2000/2003.....</b>	<b>35</b>
4.1 System Architecture .....	35
4.2 Installation and Setup.....	36

<b>5.</b>	<b>NETWARE NETWORK .....</b>	<b>38</b>
5.1	System Architecture .....	38
5.2	NetWare 3.x/4.x/5.x Installation & Setup.....	39
5.2.1	Installation Using PCONSOLE .....	39
<b>6.</b>	<b>UNIX SYSTEM NETWORK.....</b>	<b>43</b>
6.1	Introduction.....	43
6.2	Enable Print Server's TCP/IP Support .....	43
6.3	Setup Print Server's IP Address.....	44
6.3.1	DHCP .....	44
6.3.2	BOOTP.....	44
6.4	Verify Print Server's IP Address .....	46
6.5	Remote LPD Printing on the Host .....	46
<b>7.</b>	<b>CONFIGURATION UTILITY.....</b>	<b>48</b>
7.1	Introduction.....	48
7.2	Search for All Available Print Server .....	49
7.3	Status of Print Server .....	50
7.4	Setup the Print Server .....	51
7.5	General Configuration .....	52
7.6	TCP/IP Configuration .....	53
7.7	Netware Print Server Configuration .....	55
7.8	AppleTalk Configuration .....	56
7.9	SNMP Configuration.....	57
7.10	SMB Configuration .....	58
7.11	System Configuration .....	59
7.12	Wizard .....	60
7.13	Report.....	64
<b>8.</b>	<b>WEB MANAGEMENT .....</b>	<b>65</b>
8.1	Introduction.....	65

8.2	Login.....	65
8.3	Device Status .....	66
8.3.1	System .....	66
8.3.2	Printer.....	67
8.3.3	TCP/IP.....	68
8.3.4	SMB .....	69
8.3.5	SNMP .....	70
8.3.6	NetWare .....	71
8.3.7	AppleTalk .....	72
8.4	Setup Wizard.....	73
8.4.1	System .....	73
8.4.1.1	Advanced Settings .....	74
8.4.2	TCP/IP.....	75
8.4.3	SMB .....	76
8.4.4	SNMP .....	77
8.4.5	NetWare .....	78
8.4.6	AppleTalk .....	79
8.4.7	Save Settings.....	80
8.5	System Tools.....	81
8.5.1	Load Default.....	81
8.5.2	Upgrade Firmware from Browser.....	82
<b>9.</b>	<b>IPP PRINTING .....</b>	<b>83</b>
9.1	Introduction.....	83
9.2	System Setup .....	83
9.2.1	Print Server Side.....	83
9.2.2	Client Side.....	83
<b>10.</b>	<b>WINDOWS XP SP2 SETUP .....</b>	<b>88</b>

# 1. Introduction

## 1.1 Product Introduction

Thank you for purchasing and using our print server. This print server allows your printer to become a shared device on the network. It offers printing flexibility and manageability on your Local Area Network at an extremely low cost and with an absolute minimum setup and maintenance required.

This print server provides an Ethernet network port (10/100Mbps Ethernet) and one print port for printer connection. It supports IPX/SPX, NetBEUI, TCP/IP and AppleTalk protocols, and is the best network printing solutions for various common network operating systems such as Windows 95/98SE/Me/NT/2000/XP/2003, NetWare, Unix/Linux and MAC OS, etc.

With the help of Installation Wizard, you can easily and instantly complete the settings for the printing environment, and start enjoying the fantastic features provided by the print server.

This manual will introduce in detail the printing features, installation methods, and system configuration for different network environments.

If you would like to set up and install print server quickly, please refer to the Quick Installation Guide that comes along with this print server.

### Product Package

- ◆ Print Server
- ◆ Quick Installation Guide
- ◆ User manual and Utility CD
- ◆ Power Adapter

# 1.2 Network Printing Architecture

This section illustrates how print server functions and operates on the network. Before you install and use print server, it is strongly recommended that you read this section completely, and select only the chapters you need according to your network operating system by “Contents of the User’s Manual” in next section.

This section will first introduce the role every component plays in the network-printing environment.

- Print Server
- Client User
- Network Server (optional)

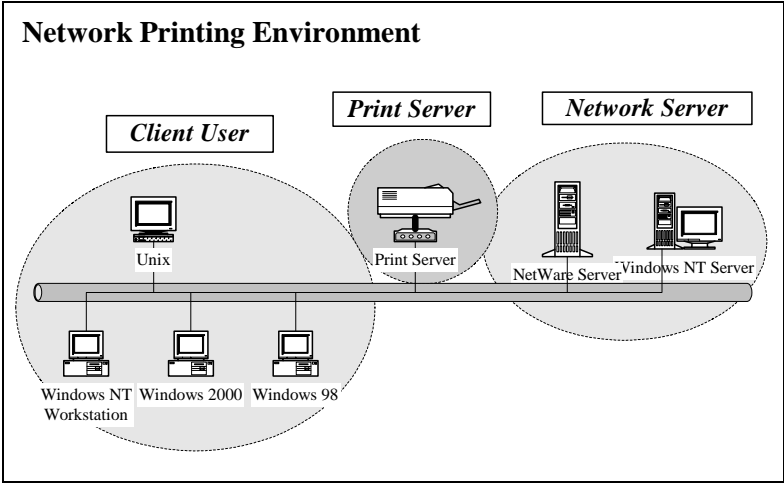

# 1.2.1 Print Server Network Functions

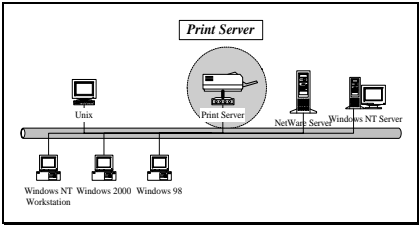

Because print server supports IPX/SPX, NetBEUI, TCP/IP and AppleTalk network protocols, any networked computer can directly print to the print server from any of its installed protocol.

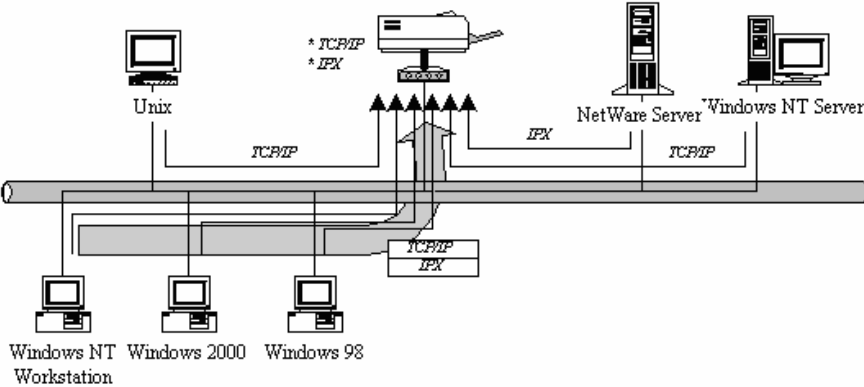

## 1.2.2 Network Printing Functions for Clients

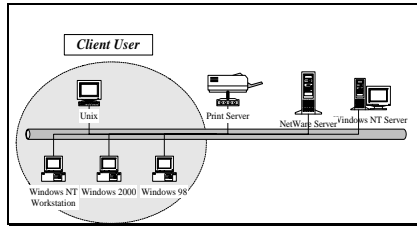

Common operating systems for clients are classified as following:

Windows 95/98SE/Me/NT/2000/XP/2003

Our print server system provides PTPP (Peer-to-Peer Printing) driver and utilities for Windows 95/98SE/Me/NT/2000/XP/2003 users. PTPP (Peer-to-Peer Printing) supports TCP/IP protocol.

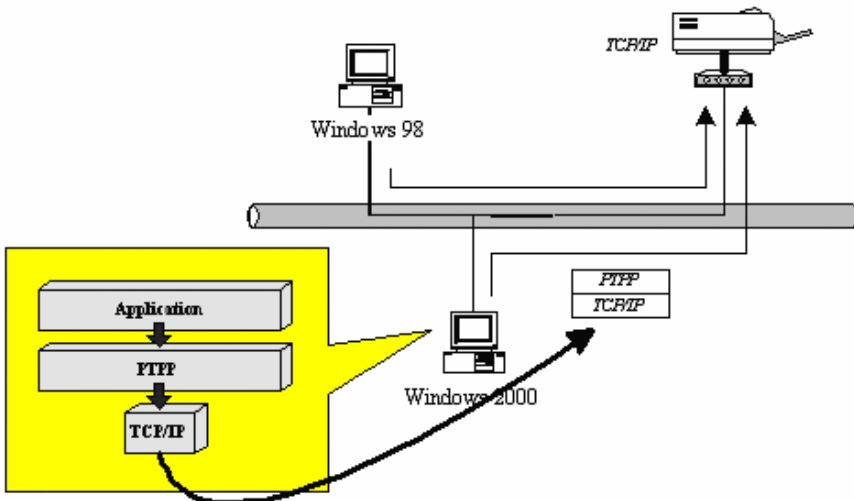

In the client installation procedure, after PTPP (Peer-to-Peer Printing Driver) is installed into Windows, the system will automatically (manual configuration is also allowed) search all the print servers on the network, and then add their printing ports into Windows' printing port (see below).

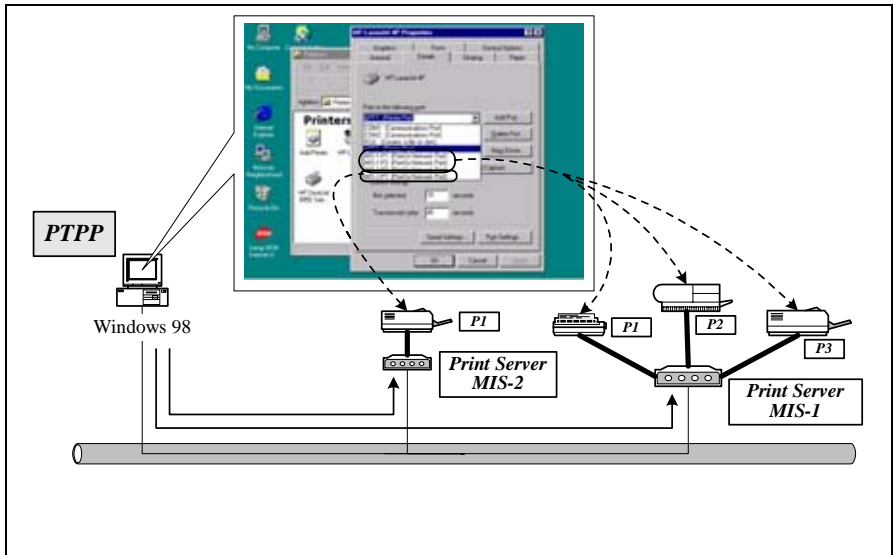

## UNIX / Linux

UNIX (include HP/UX, SCO Unix, SunOS, Solaris, Unixware DECUnix, IBM AIX and others) and Linux use the system-standard LPR to print through print server.

## MAC OS

MAC OS can use the system-standard AppleTalk network to print through print server.

## 1.2.3 Network Printing Functions for Network Server

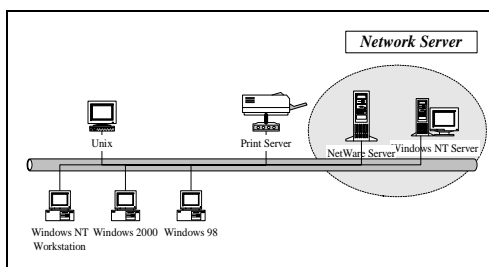

Common network servers are classified as following:

### Windows NT/2000/2003

Our print server system provides PTPP (Peer-to-Peer Printing) driver and utilities for Windows NT/2000/2003. After PTPP is installed, the server can directly print through print server. Adding this printing function into Windows NT/2000/2003 Server allows print queue, user authority management, and many other advanced features to be used.

### NetWare 3.x/4.x/5.x

In NetWare environment, print server offers various printing modes like print queue, remote printer, etc.

# 1.3 Network Printing Environment

Common network environment are classified as following:

## Windows Peer-to-Peer Network

The client's PTPP driver will use TCP/IP protocol to print through print server.

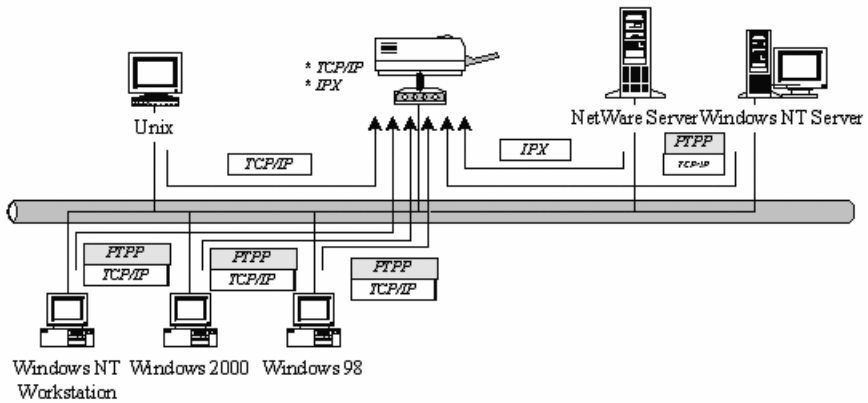

## Windows NT/2000/2003 Network

Network printing function will become available after PTPP driver is installed into Windows NT/2000/2003. Adding this printing function into Windows NT/2000/2003 Server allows print queue, user authority management, and many other advanced features to be used.

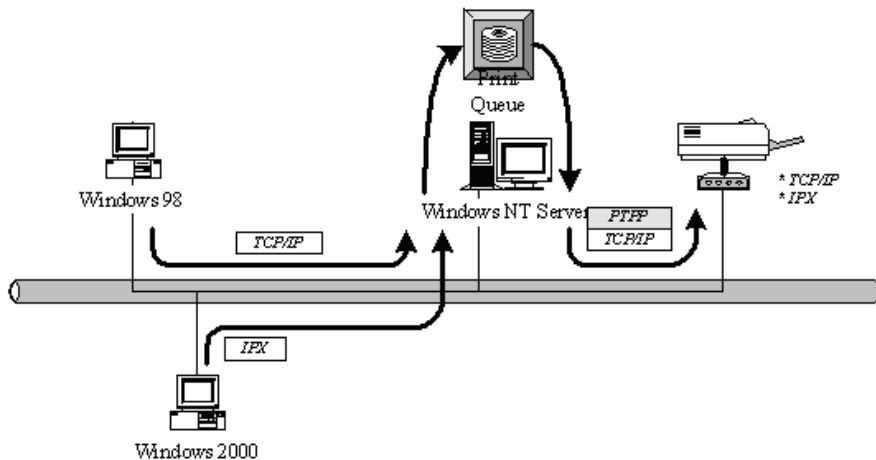

NetWare Network (see below)

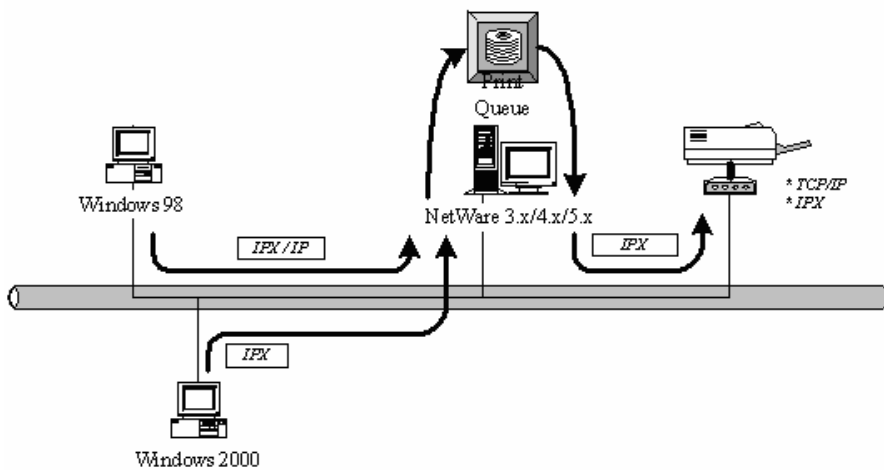

## 1.4 Contents of the User's Manual

Chapter 2. explains print server's hardware installation and configuration. It is strongly recommended for you to read.

The following chapters introduce:

Chapter 3. Windows Peer-to-Peer Network

Chapter 4. Windows NT/2000/2003 Server-Based Network

Chapter 5. NetWare Network

Chapter 6. UNIX System Network

You may select the appropriate chapters and sections to read depending on your network printing's requirement.

Chapter 7 and chapter 8 introduce print server's management and configuration utilities on Windows and Web Browser's environment respectively. You may select the appropriate management utility according to the administrator's computer platform.

Chapter 9 introduces Print Server's IPP Printing function and setup procedure. The IPP Printing provides a convenient way to print documents across the Internet by the IPP protocol.

Chapter 10 introduces how to deal with the problem that if you can't find any print server listed on the "Available Ports" in "Network Ports Quick Setup" in Windows XP SP2.

## 1.5 Firmware & Printing Function

The print server provides a complete network printing solution. The feature set is listed below:

- PTPP (Peer-to-Peer-Printing)

- TCP/IP (LPR)

- IPP Printing

- NetWare Bindery Printing

- AppleTalk

- SMB Printing

## 2. Hardware Installation

Unpack the print server package and verify that all the items listed in the section 1.2 are provided.

Connect the print server to the printer you want to share on the network.

Connect the print server to your network by attached the network cable to the UTP port of the print server.

Connect the power adapter to the print server. The print server will perform the Power-On-Self-Test (POST) after it is powered on. During the POST, the Status and Ready LEDs will be on. When the LEDs are unlighted, the print server is ready.

**NOTE1:** MUST use the power adapter shipped with the print server, do NOT use any other power adapter from any sources.

**NOTE2:** To prevent the compatibility problem between print server and a few printer, it is recommended that you power on the print server before the printer.

# 3. Peer-to-Peer Network

## 3.1 System Architecture

Print server supports Windows Peer-to-Peer network printing mode, which is suitable for most medium and small network environments. Through quick and simple installation procedure, users can immediately enjoy the convenience of network printing.

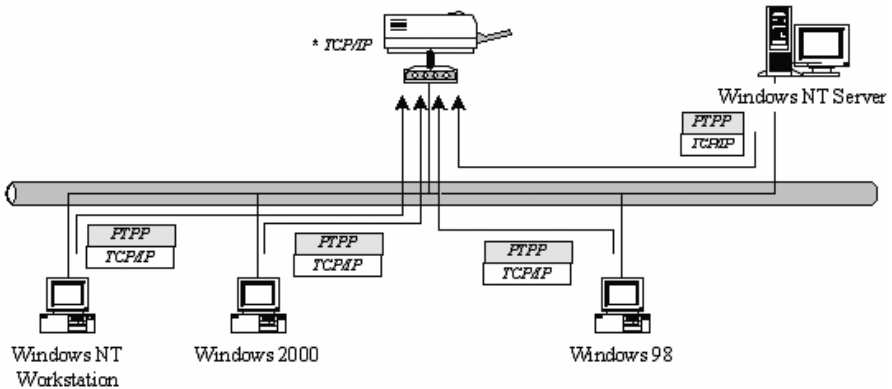

Installation procedure is separated into following two parts:

1. Administrator Installation and Setup (refer to section 2 for more detailed information).

System administrators must:

Install administrator's utilities into his/her computer.

Configure print server from administrator's configuration utility.

2. Client Installation and Configuration (refer to section 3 for more detailed information).

Client users must install Windows PTPP driver (Peer-to-Peer Printing) for network printing.

In addition, after PTPP is installed, the system will automatically search for all print servers on the network, and add the printing port of the print

servers into Windows' printing port (refer to Network Printing Architecture in section 1.4 for more detailed information).

## 3.2 Administrator Installation and Setup

The Administrator Installation can be performed on Windows 95/98SE/Me/NT/2000/XP/2003 with the same user interface. Before the installation, please verify that your network protocol is installed on your PC (TCP/IP, IPX and/or NetBEUI). It will be helpful in your installation process.

Insert the CD shipped along with the print server into your CD-ROM drive. The Autorun.exe program should be executed automatically. If not, run Autorun.exe manually from CD-ROM drive's root directory.

The "Installation Manager" will be displayed on the screen as following. Click "Administrator Installation".



The "Utilities Setup" window will be displayed. Click "Next".

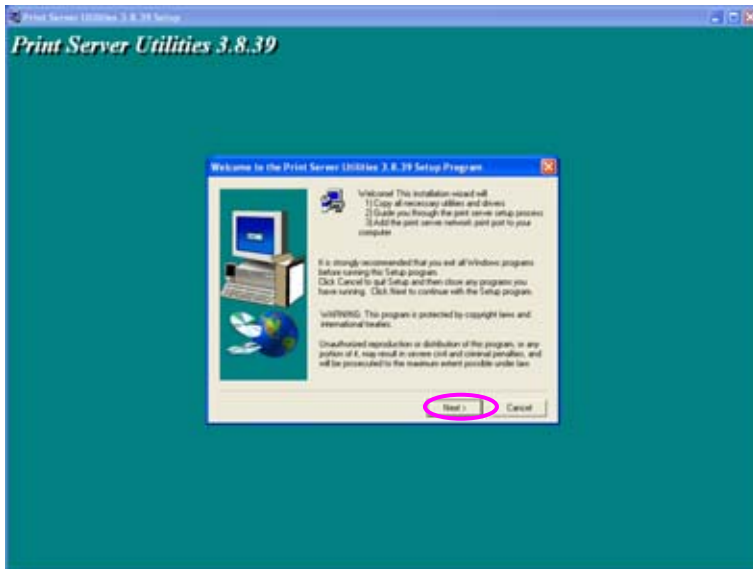

Click "Next" to install the utilities in the default folder or click "Browse" to specify the destination folder where you would like to install the utilities.

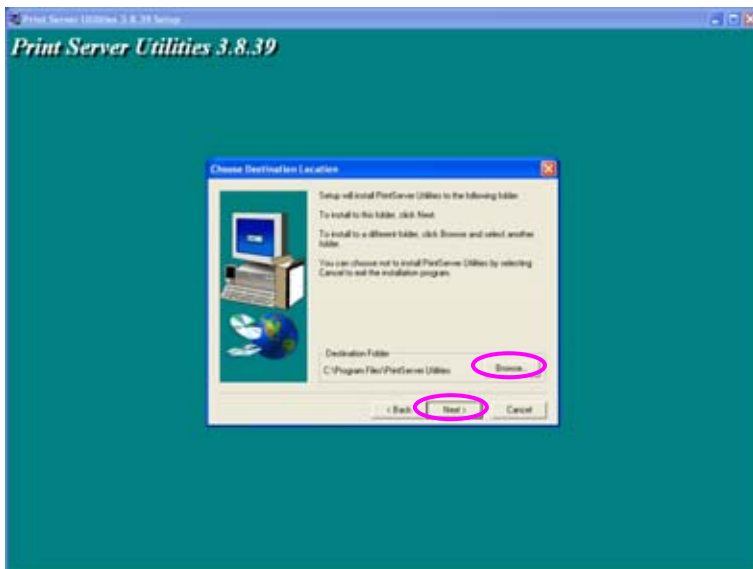

Select the components you want to install. It is highly recommended to install all provided components. Click “Next” to continue.



Specify the program folder where the program icons will be added to, click “Next”.



The system will start to install the utilities automatically.

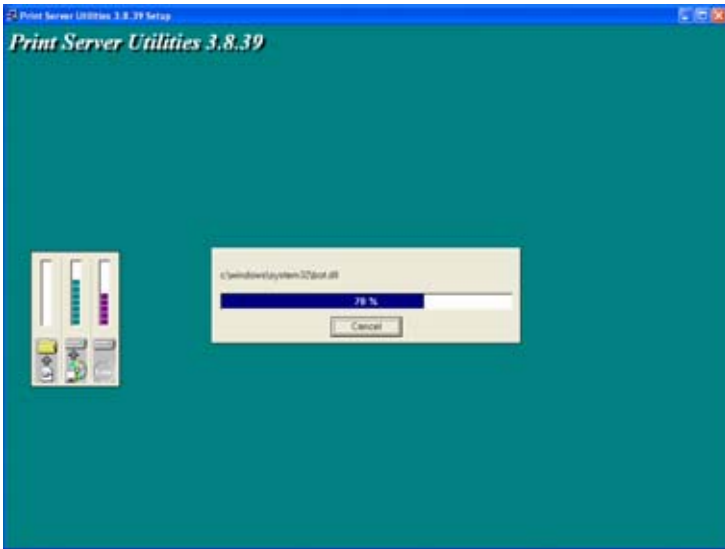

You have completed the installation phase and prepare to configure the Print Server. The “Choose Print Server” will list all Print Servers within the network. Select the Print Server you would like to configure and click “Next”.

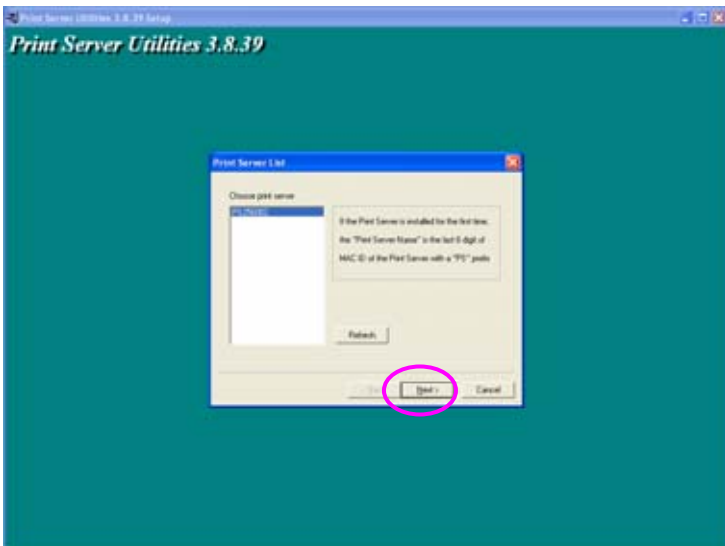

NOTE 1: If this is the first time you configure the Print Server, the “Print Server Name” is the last 6-digit of MAC ID with prefix “PS”. Please check the MAC ID on the print server.

NOTE 2: The list can only display the devices from the same manufacturer.

Specify a recognizable name for the Print Server and click “Next”.

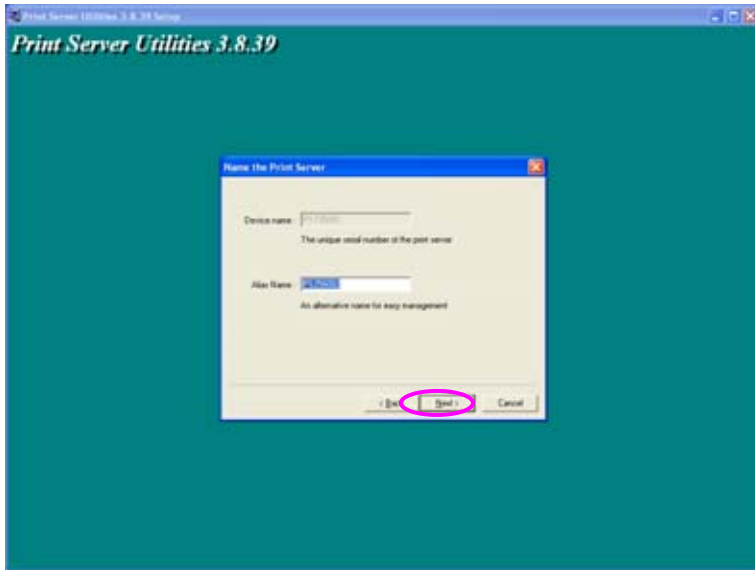

Specify the IP Address for the Print Server manually or click “Next” to keep default IP Address, i.e. 192.168.2.2.

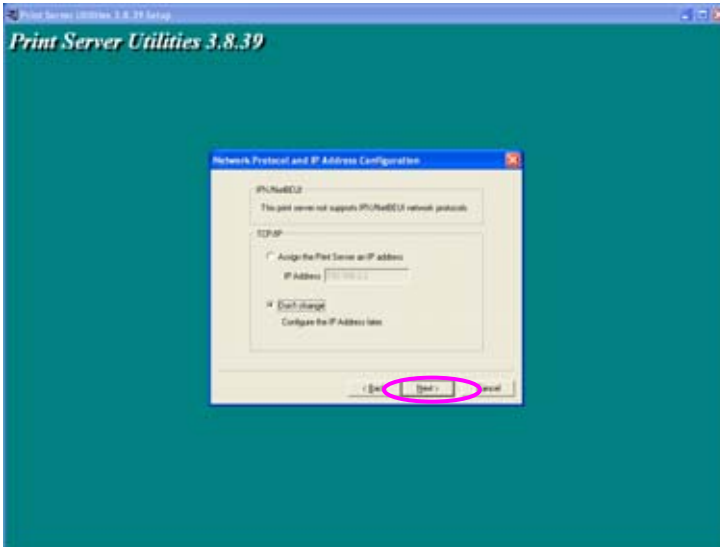

The configuration summary is displayed in the window. Now, you have completed the “Print Server Setup”. Click “Finish” and your system will add network port of the Print Server to your PC automatically.

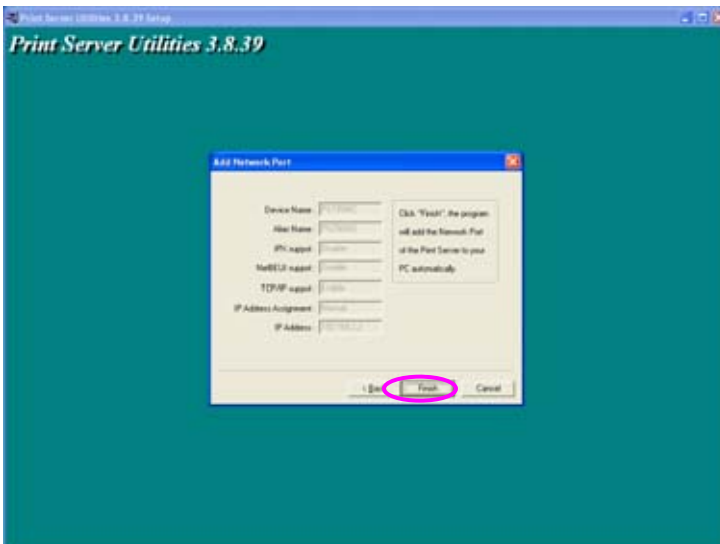

The Administrator Installation procedure is totally completed. Click “Finish”.



The Administrator Installation Program have executed the installation procedure that performs the following tasks:

Install all utilities and drivers to the administrator's PC.

Configure the print server (including the print server name and network protocol)

Add the network port of the print server to the administrator's PC.

If you want to print from this administrator's PC to the print server, all you need to do is to perform Windows' standard "Add Printer" procedure (please refer to Section 3.6).

### 3.3 Administrator Utilities

After Administrator Installation is completed, there will be four utilities in print server's Program folder.

Network Ports Quick Setup – Add the network ports of print servers within the network to your PC.

Print Server Configuration – Allows you to configure the print server's IP Address, network protocols and other advanced functions. Please refer to Chapter 7 for the detail instruction of the configuration.

Remote Ports – Add the network port of remote printer server to your PC.

Uninstall – Assistant for removing all installed administrator software.

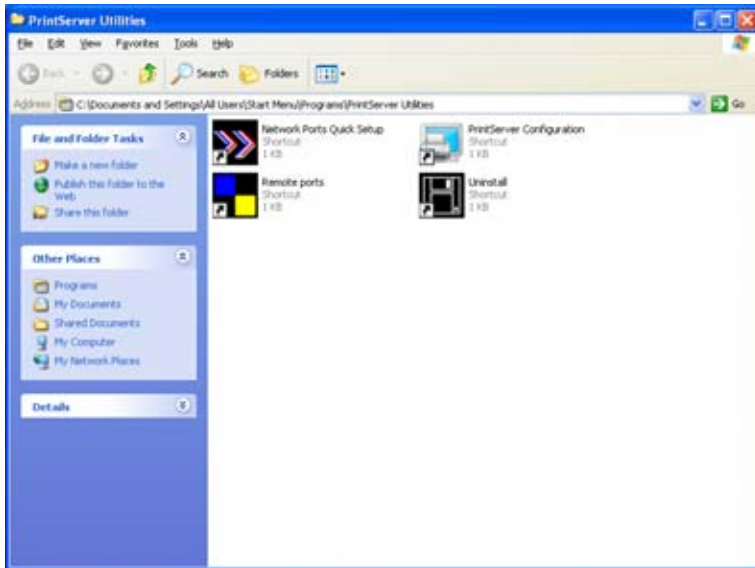

## 3.4 Client Installation and Setup

The Client Installation can be performed on Windows 95/98SE/Me/NT/2000/XP/2003 with the same user interface. Before the installation procedure, please confirm that your PC has connected to the network and installed at least one network protocol.

Insert the CD shipped along with the print server into your CD-ROM drive. The Autorun.exe program should be executed automatically. If not, run Autorun.exe manually from CD-ROM drive's root directory.

The "Installation Manager" will be displayed on the screen as follows. Click "Client Installation".



The "Utilities Setup" window will be displayed. Click "Next".



Click “Next” to install the utilities in the default folder or click “Browse” to specify the destination folder where you would like to install the utilities.

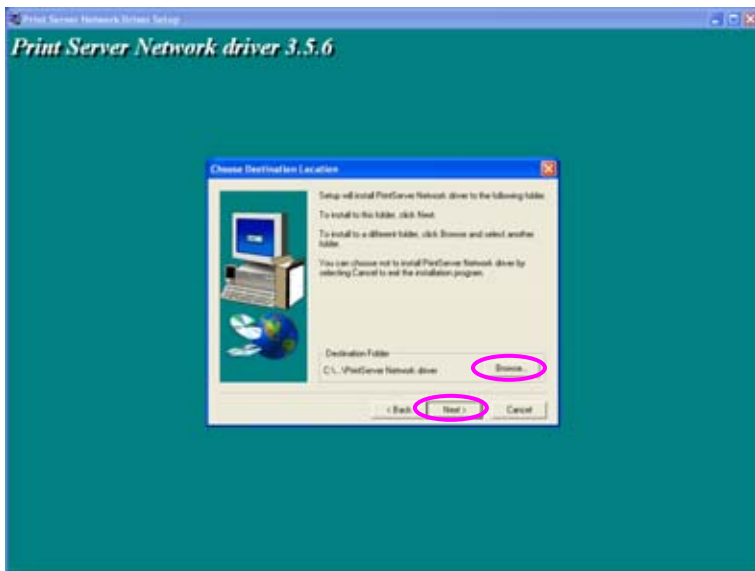

Specify the program folder where the program icons will be added to, click “Next”.

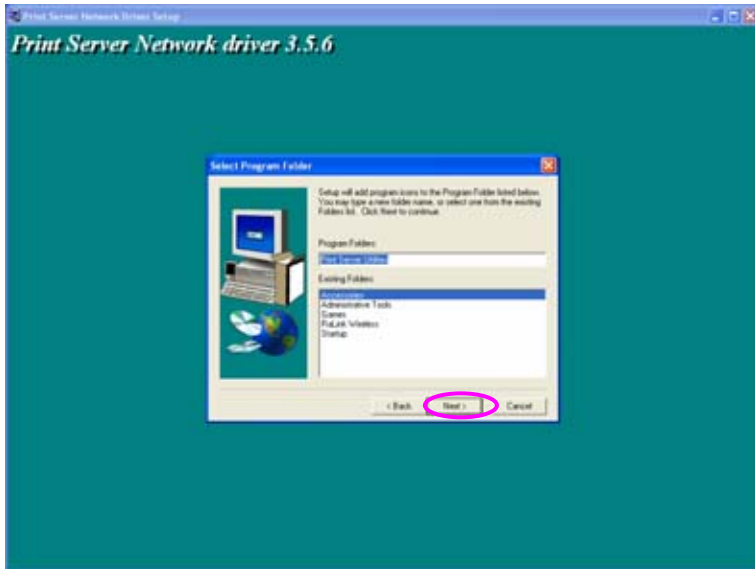

The system will start to install the utilities automatically.

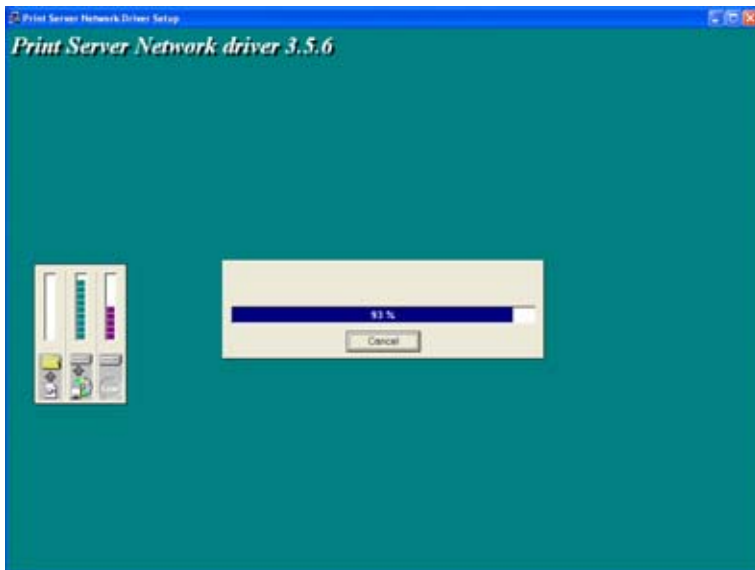

Now, the installation procedure is completed, you are ready to set up the client's computer. All network ports of the Print Servers detected on the network will be added to your PC automatically, click "Continue".

Note that if there are no print servers detected in the network currently, please click "Continue" to finish the installation. Please refer to Section

### 3.5.1 to add network ports of print servers manually.

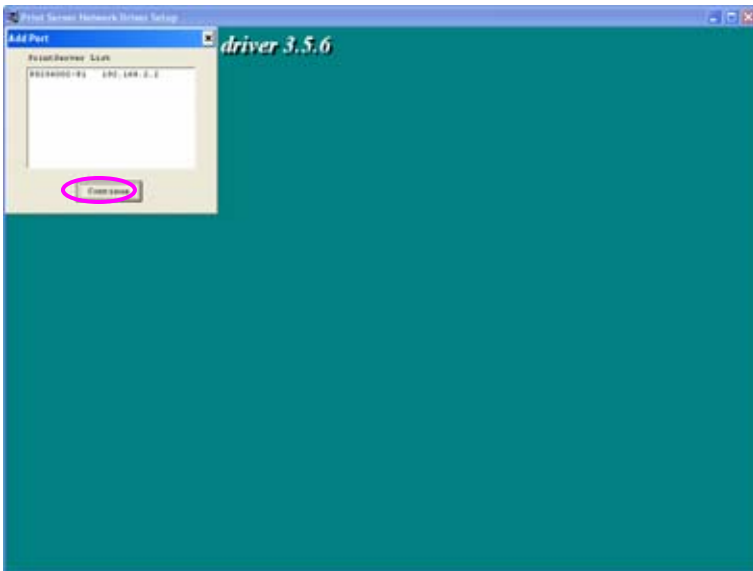

The Client Installation procedure is completed. Click "Finish".

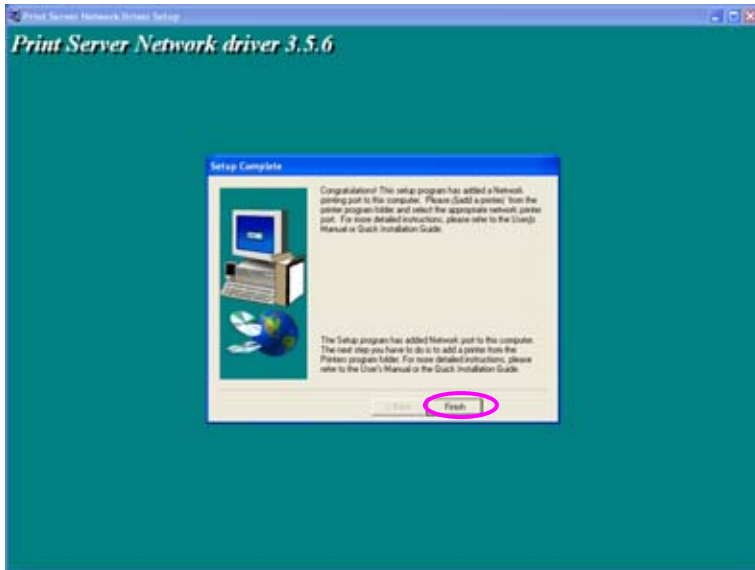

After the installation, you have completed the following tasks:

Install all utilities and drivers to the client's PC.

Add all the print server's network ports of the network to the client's PC.

You can then perform the Windows' standard "Add Printer" procedure to add network printers to your PC. Please refer to Section 3.6.

## 3.5 Client Utilities

After Client Installation is completed, there will be three tools in print server's Program folder.

Network Ports Quick Setup

Remote Ports

Uninstall Network Driver

The Uninstall Network Driver will assist you in removing all installed client software. The other two tools are described as follows.

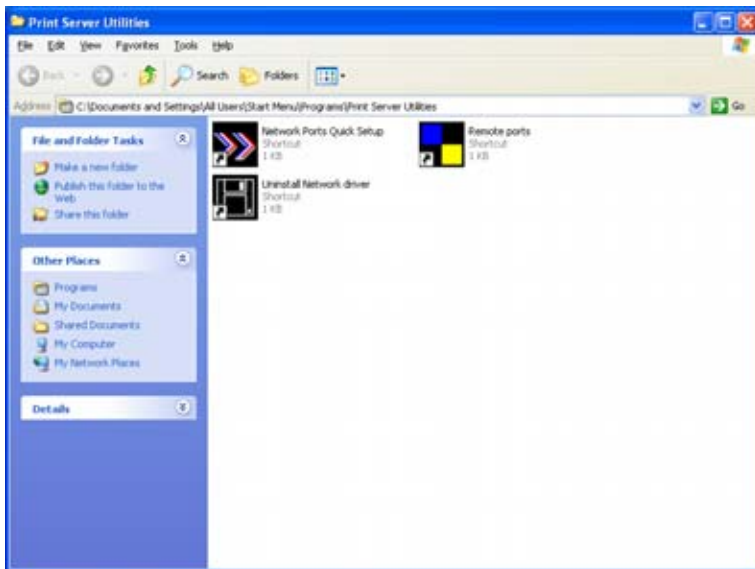

### 3.5.1 Network Ports Quick Setup

Network Ports Quick Setup Utility offers a very simple method to add or remove print server's printer port from the client's computer.

During the client's installation procedure, the system will automatically search for all print servers on the network, and add them into the printer ports of the client's computer (see below).

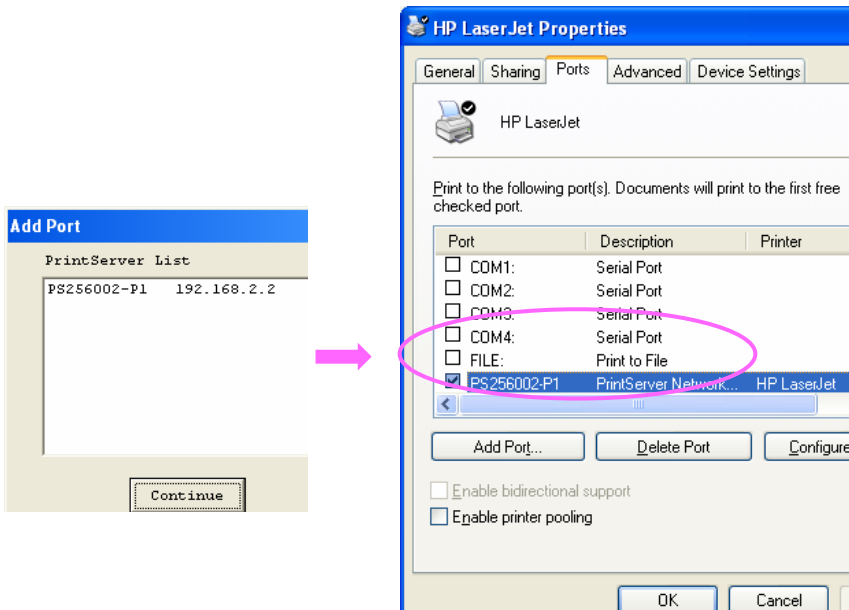

If you have just installed another new print server in the network, you must run this program first. This program will search for new print servers and allow you to add the new network printer port into client's computer conveniently. Perform the standard Add Printer procedure, then you can print directly to the printer through the newly installed print server.

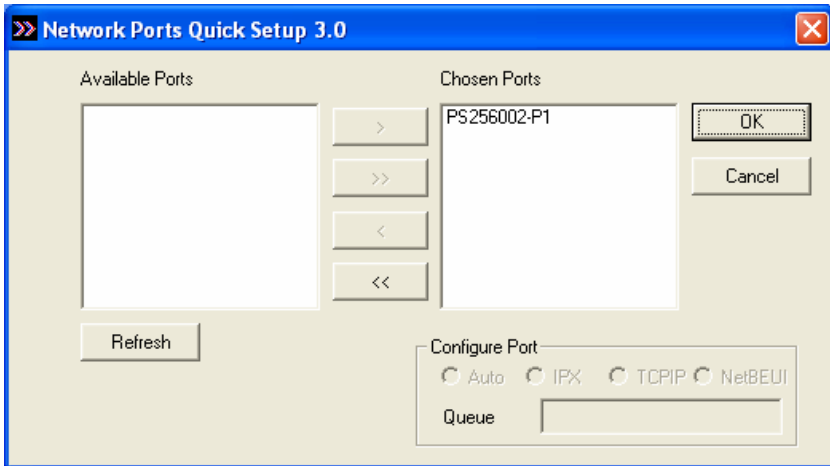

Please be aware that Network Ports Quick Setup Utility can only detect and configure all print servers on the same network, it cannot search and configure print servers on other subnets across network segments. You must use Remote Ports Utility described in the next section to manage remote (across network segments) print servers.

Select the network ports in the “Available Ports” list and click “>” to add ports. If you want to add all available ports, please click “>>”. To cancel some of the network ports or all ports from the “Chosen Ports” list, please click “<” or “<<”.

### 3.5.2 Remote Ports (Utility)

Remote Ports Utility offers a convenient way for you to manage and add printer port of the remote print server. From the assistant of this utility, you can print to other print servers outside the subnet across network segment. However, please note that this function only supports TCP/IP network protocol.

Please follow the procedures described below:

Step1. Run Remote Ports Utility. Clicks “Add” to add a remote print port.

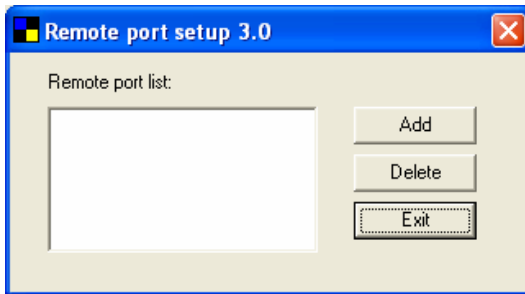

Step2. Enter print server's name, IP address, select used ports, and enter LPR queue name of each port. Click “Ok”.

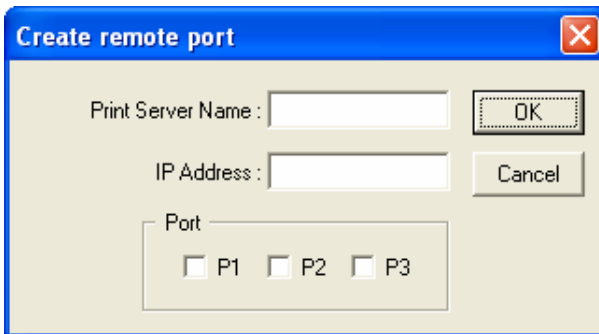

Step3. The new remote print port is displayed as follows.

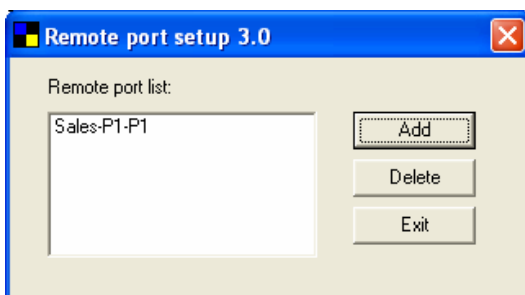

In order to use the remote printing function, you will have to proceed with normal Add Printer procedure and select your printer port as the newly added remote printer port.

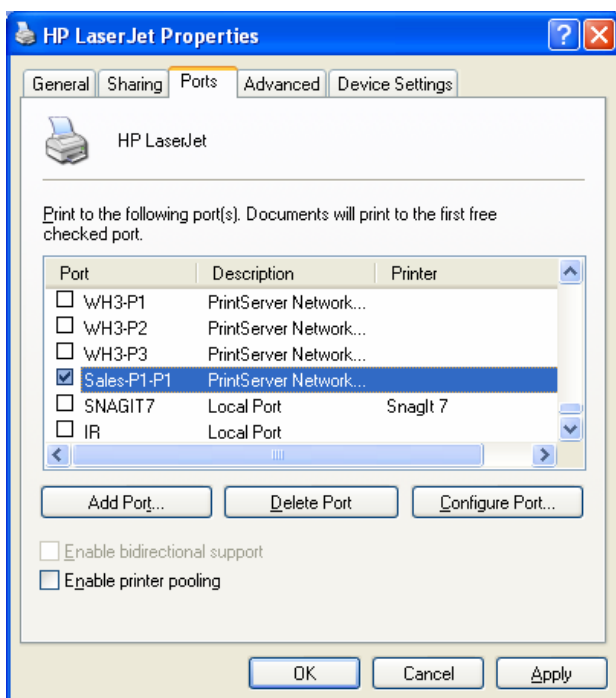

## 3.6 Windows Add Printer Procedure

After adding a **“Network Port”** of the print server to your PC by Administrator or Client Installation Program, you can follow the procedure described below to add printer to the Windows. Note that following **“Add Printer”** steps are running in Windows XP, the steps in other Operating Systems are similar.

- Step1. Click **“Start”**, choose **“Settings”** and select **“Printers and Faxes”**.
- Step2. Click **“Add a Printer”**.
- Step3. The **“Add Printer Wizard”** is displayed. Click **“Next”**.

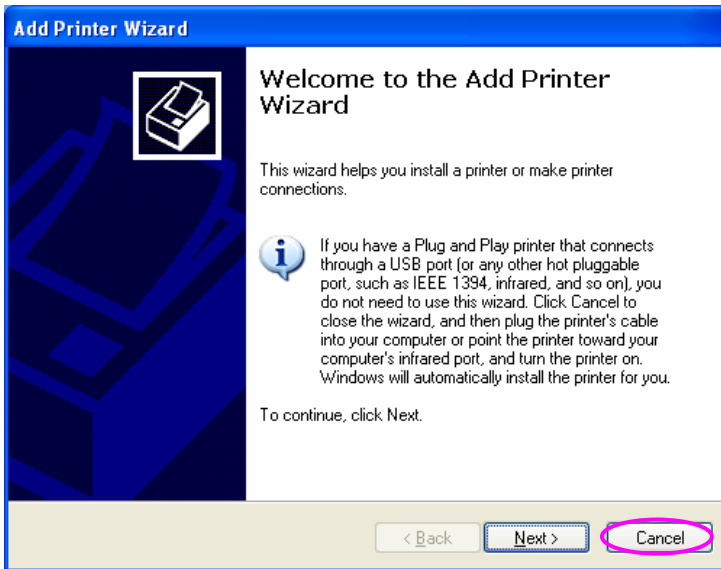

- Step4. Select **“Local printer attached to this computer”** and make sure that **“Automatically detect and install my Plug and Play printer”** is not selected. Click **“Next”**.

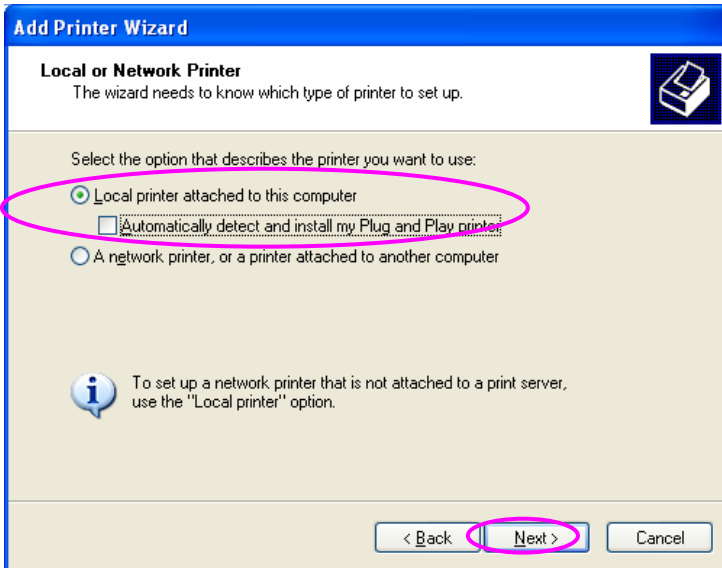

Step5. Choose the suitable **"Print Server Network Port"** which was created by the Administrator Installation or Client Installation process and click **"Next"**.

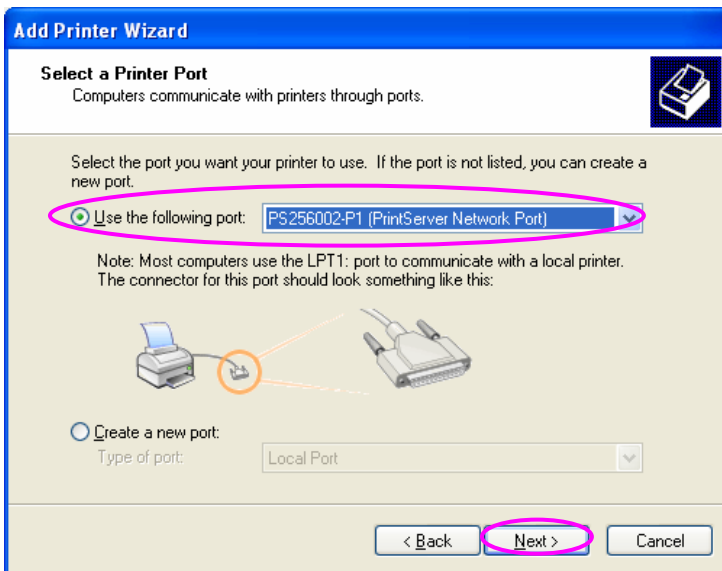

Step6. Select a suitable printer manufacturer and the printer model and click “Next”. If your printer is not in the list, click “Have Disk...” to install the driver of the printer. After installation, the printer model will be added to the list.

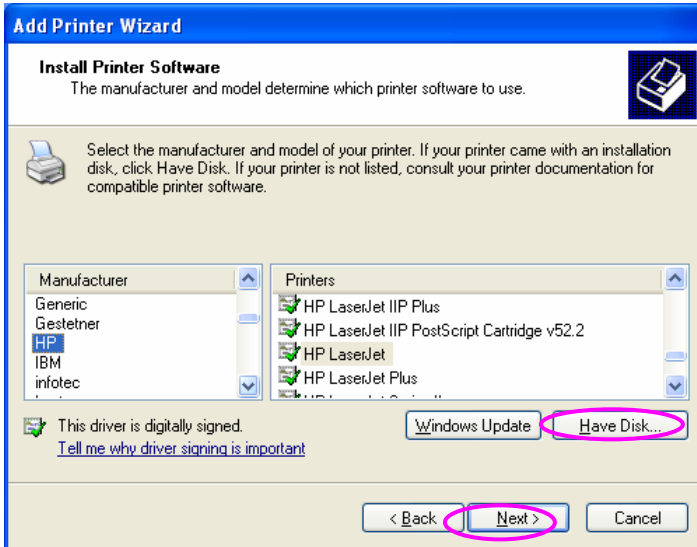

Step7. Name your printer and setup the default printer, click “Next”.

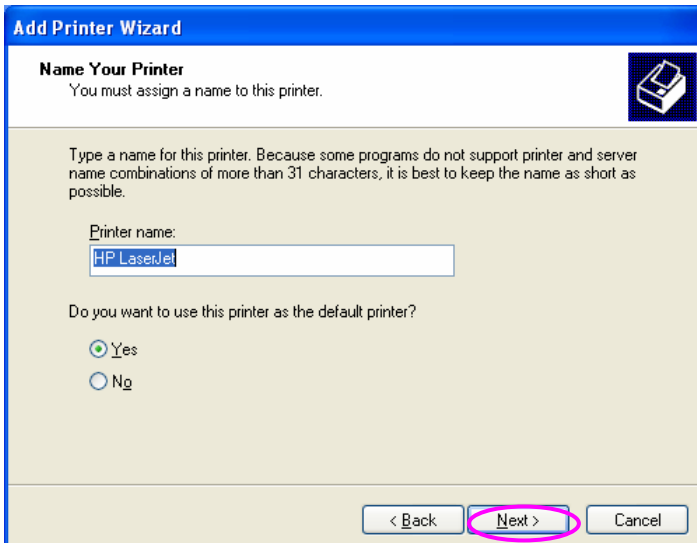

Step8. Choose to print the test page or not. It is recommended to print a test page. Click “**Next**”.

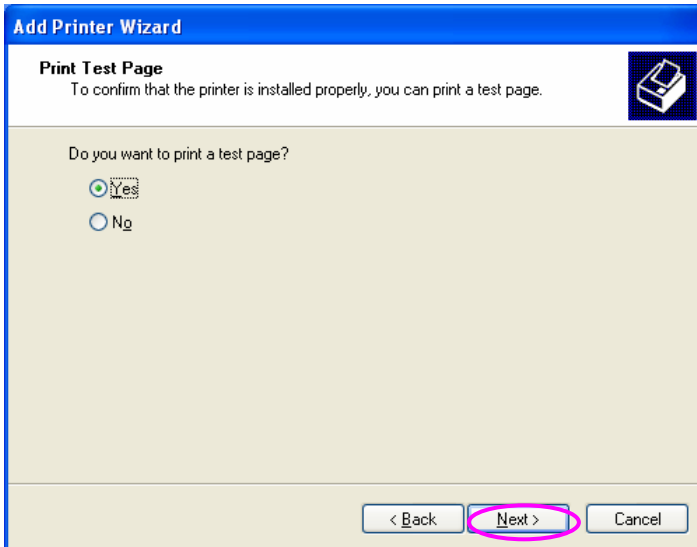

Step9. You have added the printer to the PC successfully. The information of the printer is displayed in the windows. Click “**Finish**”.

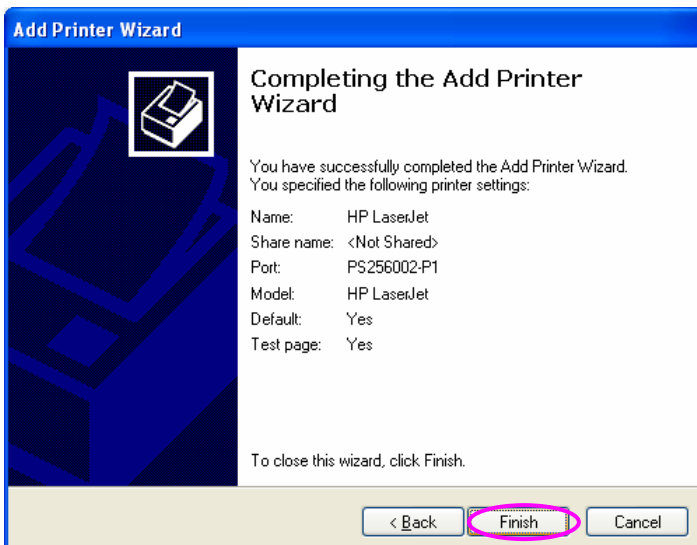

# 4. Windows NT/2000/2003

## 4.1 System Architecture

In Windows network environment, other than the Peer-to-Peer network printing architecture described in the previous chapter, we also offer the Server-Based Printing architecture for Windows NT/2000/2003 server. Only one Windows NT/2000/2003 is required to have Windows PTPP (Peer-to-Peer Printing) driver installed and share the printing service on the network. Other network users can simply connect to the server and access the shared printer (see below).

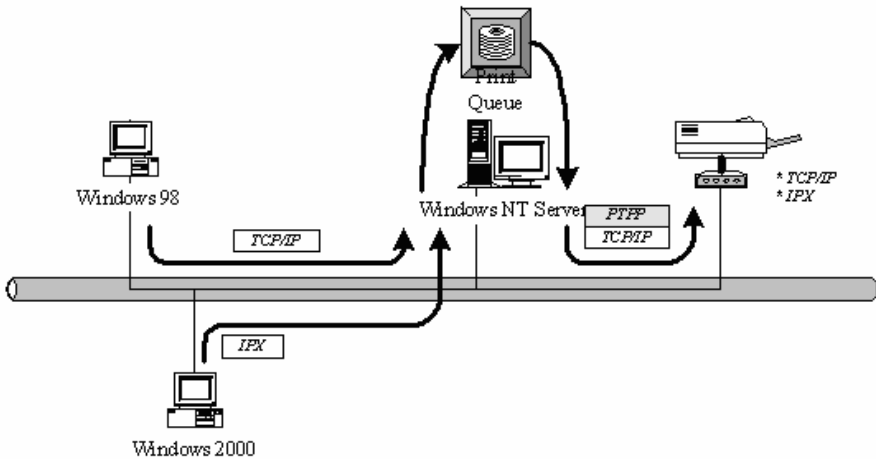

## 4.2 Installation and Setup

Please follow the procedures described below for installation and construct a peer-to-peer connection (PTPP) between Windows NT/2000/2003 Server and Print Server.

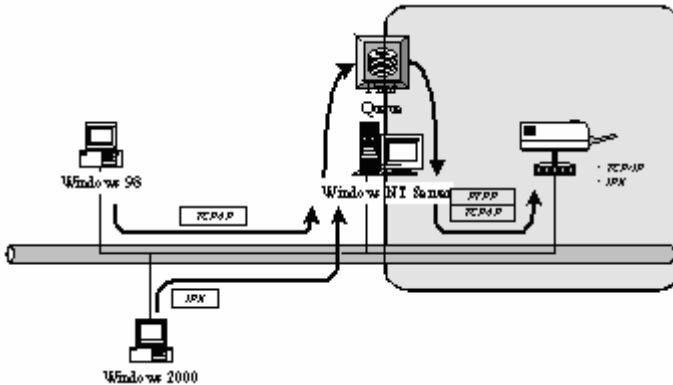

### Step1.

If this is your first time installing print server, please install the administrator software on Windows NT/2000/2003 server first. Refer to section 3.2 for installation instructions.

If your network has already installed a working print server and your Windows NT/2000/2003 server has not yet installed the PTPP driver, please install the client software. Refer to section 3.4 and 3.5 for installation instructions.

### Step2.

Please add/configure the Peer-to-Peer Printing of the Windows NT/2000/2003 network printer and verify that you can print from Windows NT/2000/2003 to the print server by the installed PTPP driver.

### Step3.

Share the above server's printer to the network by performing the standard Windows printer sharing process.

## 4.3 User Installation and Setup

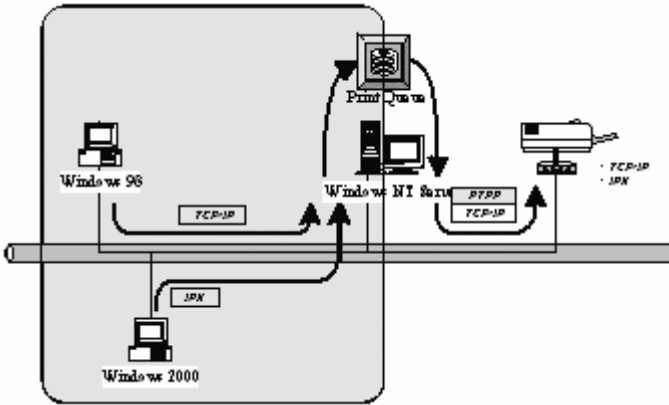

After server side's installation is completed, client side will be able to find the server's shared printer in Network Neighborhood. You only need to perform Window's standard Add New Printer procedure, select "Network Printer" shown in the screen below, and complete the configurations afterwards to access the shared printer.



# 5. NetWare Network

## 5.1 System Architecture

We implement NetWare printer sharing functionality into the print server itself, thus allowing one or more printers attached by a print server to be connected to the network. We have developed the print server to support NetWare print server.

Embedded print server, which emulates the “queue management functionality” of NetWare print server, PSERVER program running on the NetWare server. A user first prints a job at a workstation, the job is routed to a NetWare server, the NetWare server stores the job in a print queue and then the print server gets the print job from the queue to printers.

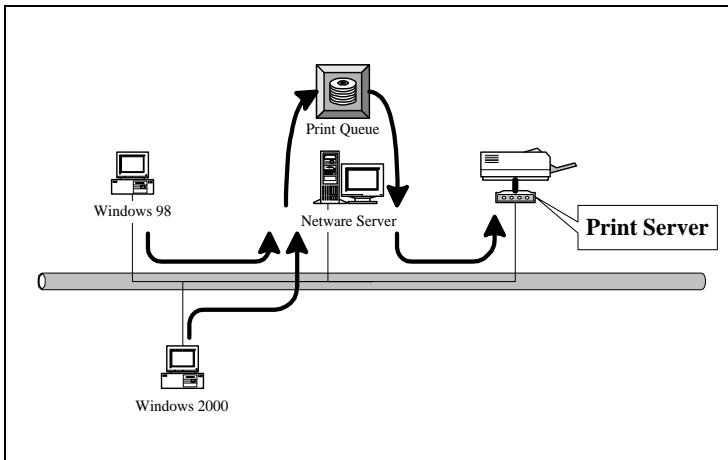

Compare with NetWare printing functionality, the advantages of embedding the NetWare network printing functionality in the print server include:

- Installation is easier and quicker.
- Network management is easier.
- Printing performance is enhanced.
- Relieve NetWare file server's burden.

Relieve the need of a workstation running the remote printer utility.

Improve productivity by locating the printer near the workgroup.

Each print server should log into a NetWare server before servicing the print jobs. Each print server will occupy a user account with which it can log into the NetWare server.

## 5.2 NetWare 3.x/4.x/5.x Installation & Setup

Once your print server is connected to your Ethernet network, you can set it up for use with your networking software.

### 5.2.1 Installation Using PCONSOLE

#### 5.2.1.1 Configuring as Print Server Mode

1. Run the NetWare PCONSOLE program.
2. Change the current file server, if necessary, using the Change Current File Server menu selection.
3. Choose the Print Queue Information menu selection.
4. Press the Insert key to add a new print queue.
5. Type in a print queue name, such as "PQ" or "Q1".

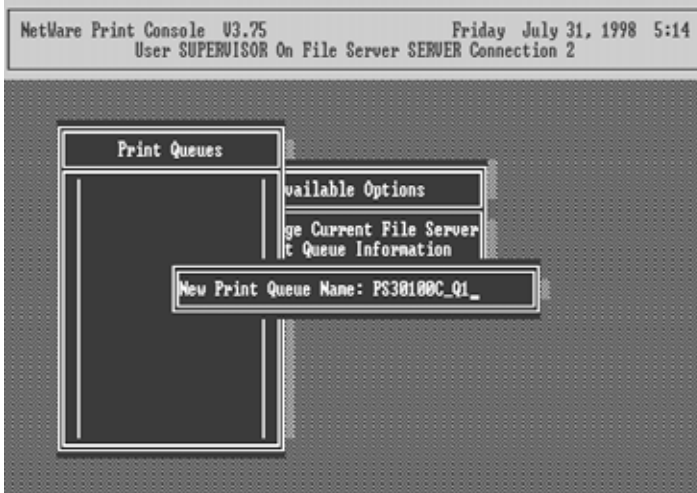

6. You have now successfully created the print queue that your print server will serve. Press the Escape key until the Available Options main menu is displayed.
7. Select Print Server Information.
8. Press the Insert key to add a new NetWare print server object. The print server name can be identical to the PSxxxxxx name printed on the label of the print server.

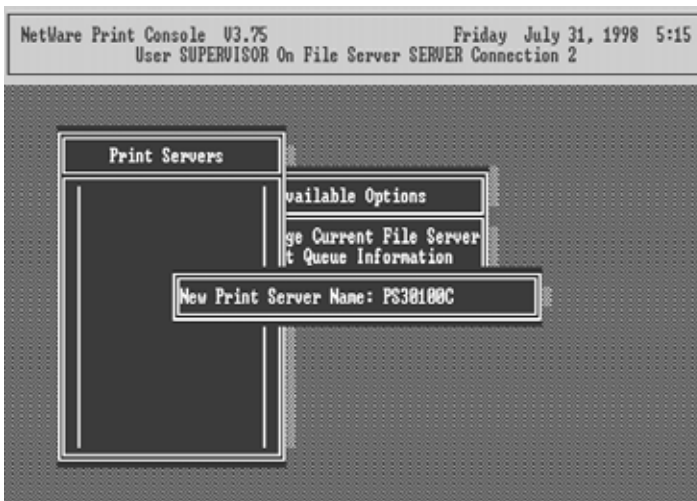

9. Press Enter to select the newly created print server.
10. Select Print Server Configuration.
11. Select Printer Configuration.
12. Select Printer 0 (or Printer 1, Printer 2), and press Enter, then select LPT1 (or LPT2, LPT3) in the Type field. If your print server is with only one port, you do not need to configure this Type field.



13. Press Escape, and answer Yes to the Save Changes question.
14. Select Queues Served by Printer, then select Printer 0 (or Printer 1, Printer 2) and press Enter.
15. Press Insert and add your newly created print queue to the list of queues serviced by the printer. Enter a priority number for the queue service, or press Enter to accept the default.

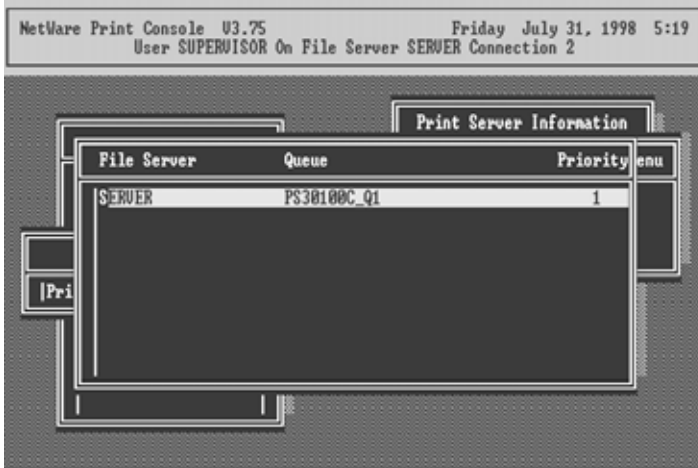

16. Repeatedly press Escape to exit the PCONSOLE program.
17. Reset the print server to have the changes take effect.

NOTE: If the print server you have is with multiple printer connectors, you may create multiple print queues and printer objects.

Your print server should now be ready to use. You should be able to redirect printing to your print server using a CAPTURE command such as the one shown in the previous section.

# 6. UNIX System Network

## 6.1 Introduction

The print server is available for TCP/IP printing by Unix LPD (Line Printer Daemon) protocol. The LPD protocol originated with Unix release is based on the BSD version of Unix and supported under most versions of Unix.

This chapter explains how to configure the print server for TCP/IP operation, and how to modify configuration files on your Unix system to allow printing to the print server. The configuration examples in this manual follow the syntax for BSD based Unix systems. Please refer to the related system documentation for the correct syntax of your systems.

To configure the print server for LPD printing, perform the procedures below:

1. Enable Print Server's TCP/IP Support.
2. Set up Print Server's IP address.
3. Verify Print Server's IP Address.
4. Configure remote LPD printing on the host.
5. Print a test page.

In the next sections, we will describe these five procedures step by step.

## 6.2 Enable Print Server's TCP/IP Support

The default configuration of the print server is with TCP/IP support enabled. Anyway, you can configure the print server to enable TCP/IP support using the configuration program.

## 6.3 Setup Print Server's IP Address

The print server must have a unique IP address in order to be recognized by the network.

You can set up the IP address on the various Unix systems using any one of the following methods:

1. DHCP (Dynamic Host Configuration Protocol)
2. BOOTP (Bootstrap Protocol)

The print server will use the last three methods to obtain its IP address automatically if its IP address is configured as Auto (0.0.0.0).

### 6.3.1 DHCP

There are many Unix systems that support DHCP protocol, and the procedures to configure the DHCP server database are different. This manual does not describe the DHCP server configuration on the Unix systems. It is highly recommended that the DHCP server should be located on the same network as the print server.

### 6.3.2 BOOTP

If you have the BOOTP daemon, `bootpd`, running on your UNIX system that is accessible by the print server, you can use the BOOTP protocol to set up the IP address of the print server. We recommend that the BOOTP server should be located on the same subnet as the print server. If you use Network Information Services (NIS) in your system, you may need to rebuild the NIS map with the BOOTP services before doing the following BOOTP configuration. To rebuild the NIS map, please refer to your system documentation.

To configure the IP address data for the BOOTP server, you will need to log in the host of BOOTP server as the superuser (root). Perform the following steps to add address entries,

1. Optionally, assign a name corresponding to the print server's IP address. You can add this address to the `/etc/hosts` file, by adding a line such as:

```
203.66.191.12          pserver
```

2. Add an entry to the host's `/etc/bootptab` file, similar to the following:

```
hostname:\
:ht=1:\
:ha=print_server_ethernet_address:\
:ip=print_server_ip_address:
```

Lines should be indented with tabs.

Where `hostname` is the device name of a print server, the `ht=1` tag specifies the hardware type is Ethernet, the `ha=` tag specifies the Ethernet address of a print server, which is the Node ID located on the print server. The `ha` tag must be preceded by the `ht` tag. The `ip=` tag should correspond to the IP address you want to assign to the print server.

For example, a print server with the following configuration:

```
Node ID: 0000B4010101 (this implies Ethernet
address is 0000B4010101),
IP address: 203.66.191.12
```

The entry for this print server in the `/etc/bootptab` file should be:

```
PS010101:\
:ht=1:\
:ha=0000B4010101:\
:ip=203.66.191.12:
```

## 6.4 Verify Print Server's IP Address

To verify that your print server is responding to the newly assigned IP address using a PING command:

```
ping ip-address
```

## 6.5 Remote LPD Printing on the Host

The procedure you use to configure your Unix host(s) to allow printing to your network remote print server varies between different varieties of Unix. The procedure below can be used for Unix variants that are related to BSD Unix, such as SunOS or Linux. For other versions of Unix, consult your system documentation, keeping in mind that:

1. The print server should be treated as a BSD networked print server host.
2. The host name should be the name (or IP address) that you have assigned to the print server.
3. The printer name (or queue name) on the remote host should be `lpt1`, `lpt2` or `lpt3`, the name of the printer port on the print server.

You will need to perform the tasks below, logged in as the superuser (root). To configure your Unix host for printing,

1. Optionally, assign a name corresponding to the print server's IP address. You can add this address to the `/etc/hosts` file, by adding a line such as:

```
203.66.191.186 pserver
```

2. Create a spool directory for the printer in the same directory where spool directories are normally kept on the machine, such as `/var/spool` or `/var/spool/lpd`:

```
mkdir /var/spool/lpd/pserverd
```

```
chown daemon /var/spool/lpd/pserverd
```

```
chgrp daemon /var/spool/lpd/pserverd
chmod 775 /var/spool/lpd/pserverd
```

3. Add an entry to the host's `/etc/printcap` file, similar to the following:

```
printer-name:\
:lp=\
:rm=203.66.191.186:\
:rp=lpt1:\
:lf=/var/spool/lpd/pserverd.log:\
:sd=/var/spool/lpd/pserverd:\
:mx#0:
```

Lines should be indented with tabs. More than one printer name can be used, with variants separated by vertical bars (name1|name2).

The `rm=` entry should correspond to the IP address you have assigned to the print server. You can also use a host name if you have assigned one in the `/etc/hosts` file.

The `sd=` entry should correspond to the spool directory you created in the previous step.

The `rp=` entry should correspond to the port name of the remote printer. The values should be one of `lpt1`, `lpt2` or `lpt3` depends on the printer port.

The print server should now be available for printing from your Unix host.

# 7. Configuration Utility

## 7.1 Introduction

This chapter introduces print server's system configuration utility in Windows environment. This utility is automatically installed during Windows Administrator Utility installation procedure - refer to section 3.2 and 3.3.

This utility provides the most complete management and configuration functions on the print server side. This utility only provides configuration functions for print server itself; it does not include configuration functions for client side or other file server or NetWare server in the network environment.

The Configuration Utility provides the following configuration and management functions:

- Search Print Server: Search All Available Printer Servers on the Network.
- Print Server Status: Display Print Server Network Status.
- General Configuration: General Information of print server.
- TCP/IP Configuration: IP Address and DHCP Server Configuration.
- NetWare Configuration: NetWare Printing Configuration.
- AppleTalk Configuration: AppleTalk Protocol Setting.
- SNMP Configuration: SNMP Information Configuration.
- SMB: Configure the SMB Group Name.
- System Configuration: Print Server Network Ability Setting and Firmware Upgrade.
- Setup Wizard: Guide You Through All the Settings.
- Report: List the Status of All Available Print Servers on the Network.

We will explain each function separately in the following section.

## 7.2 Search for All Available Print Server

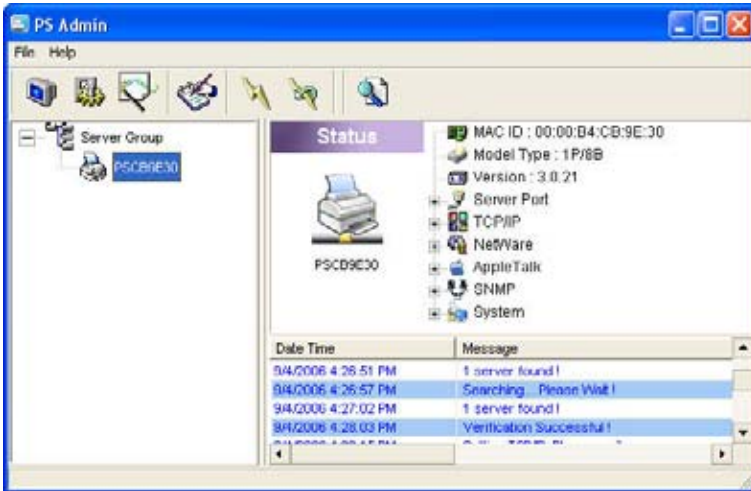

Every time when you run print server's configuration utility, click the

"Search" icon  on the tool bar. The configuration utility will delay for several seconds because the utility is using system's available network protocols to search for all print servers on the network. All available print servers will be listed under "Server Group" on the left side of the window.

You must select the print server you would like to configure from the list. The system will, at the same time, display the selected print server's status on the right side of the window.

## 7.3 Status of Print Server

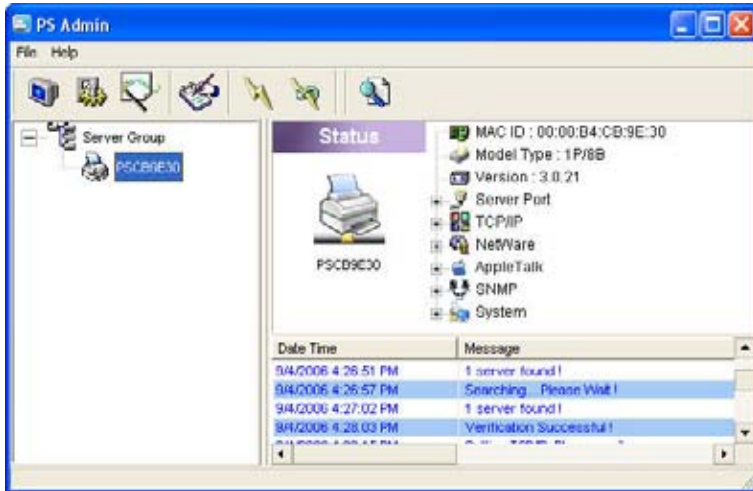

Click "**Status**" icon on the tool bar, the status of the current selected print server will be showed on the right side of the window.

The information of the print server displayed are MAC ID, Model Type, Firmware Version, status of each printer port, NetWare file server name, NetWare file server polling interval, NetWare printer queue names, IP address, subnet mask, default gateway, AppleTalk printer type, AppleTalk zone and print server printing ability...etc.





You can press the "**Refresh**" button to refresh the print server's

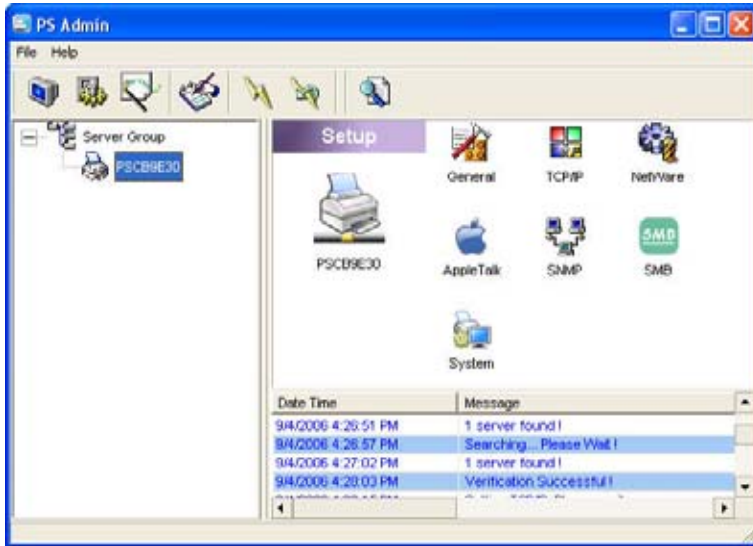

status or press the "**Reboot**" button to restart the print server.

## 7.4 Setup the Print Server



Click **"Setup"** icon  on the tool bar, the setup items of the current selected print server will be showed on the right side of the window.

Double click one of the icons to set up the selected print server. A screen will pop up to verify **"User Name"** and **"Password"** of the print server. The default values are as follows.

User Name: admin

Password: 1234

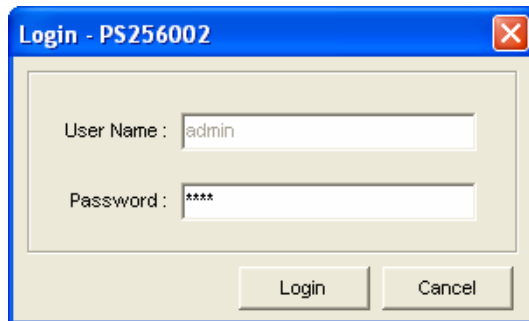

## 7.5 General Configuration

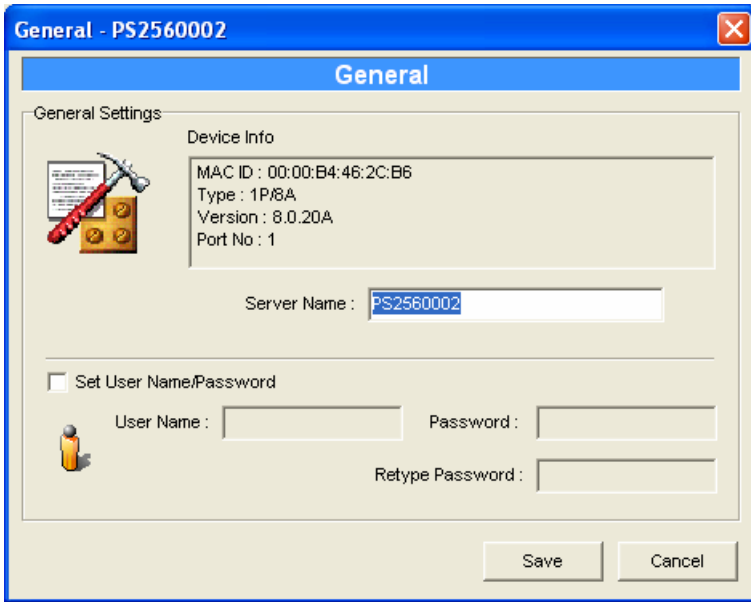

Double Click “General” icon and the General configuration window will pop-up.

You can see basic print server information in this page. You also can configure the “Server Name”, “User Name” and “Password” here.

Server Name, the name of the print server. You can use this name to identify the print server when you are searching for the print server by the administration and client utilities.

User Name / Password is used to authenticate the administrator by the Web administration tool.

## 7.6 TCP/IP Configuration

The screenshot shows a window titled "TCP/IP - PS256002" with a close button in the top right. The main title bar is blue and contains the text "TCP/IP". Below the title bar, the text "TCP/IP Settings" is displayed. On the left side, there is a Windows logo icon. To the right of the logo, there are two tabs: "IP" (selected) and "DHCP Server". Below the tabs, there are two radio buttons: "Auto IP" (unselected) and "Static IP" (selected). In the center, there is a table for static IP configuration:

IP Address :	192	168	2	2
Subnet Mask :	255	255	255	0
Gateway :	0	0	0	0

At the bottom right, there are two buttons: "Save" and "Cancel".

The screenshot shows a window titled "TCP/IP - PS256002" with a close button in the top right. The main title bar is blue and contains the text "TCP/IP". Below the title bar, the text "TCP/IP Settings" is displayed. On the left side, there is a Windows logo icon. To the right of the logo, there are two tabs: "IP" (unselected) and "DHCP Server" (selected). Below the tabs, there are three radio buttons: "Auto" (unselected), "Enable" (unselected), and "Disable" (selected). In the center, there is a table for DHCP server configuration:

Starting Address :	0	0	0	0
Range :	0			
Subnet Mask :	0	0	0	0
Gateway :	0	0	0	0
DNS :	0	0	0	0

At the bottom right, there are two buttons: "Save" and "Cancel".

Double Click “TCP/IP” icon and the TCP/IP configuration window will pop-up.

You can configure the print server to automatically get IP from DHCP server or manually specify static IP. The print server also has a built-in DHCP server. You can enable this DHCP server and let it manages IP for you.

Click the “IP” button to enter the IP setting page. If you need the print server to automatically get an IP from DHCP server, select “Auto IP”. You also can select “Static IP” to manually assign “IP Address”, “Subnet Mask” and “Gateway” for the print server.

Click the “DHCP Server” button to enter the DHCP server's setting page. You can “Enable/Disable” the DHCP server or set “Auto” and assign a range of IP addresses here. The DHCP server is disabled by default. If Auto is selected, the DHCP Server of print server will be enabled only when there is no other DHCP Server within the network. When “Enable” or “Auto” is selected, you have to configure “Starting Address”, “Range”, “Subnet Mask”, “Gateway” and “DNS”. The print server will assign a unique IP for each client.

## 7.7 Netware Print Server Configuration

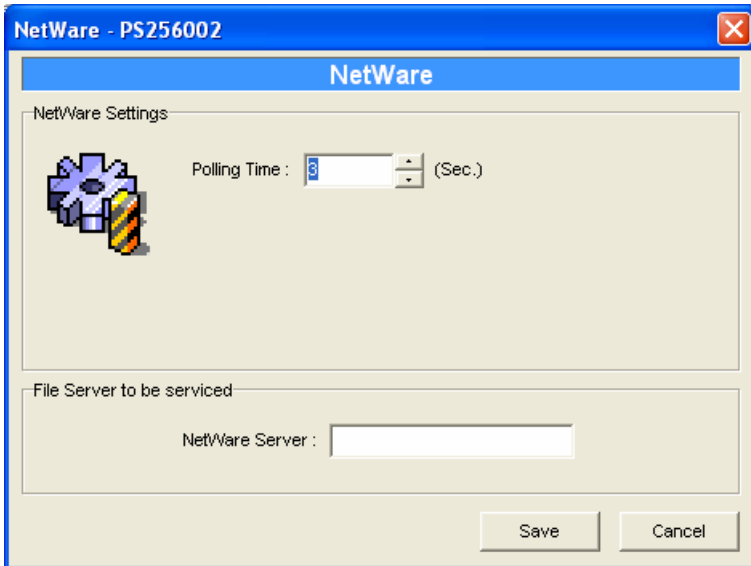

Double Click “NetWare” icon and the NetWare configuration window will pop-up.

This print server supports NetWare Bindery Printing method. The print server periodically polls the NetWare server printer queues for printing jobs. You have to assign the NetWare server name, print server polling interval and the name of queue on the NetWare server for each printer port.

Polling Time is the polling interval of the print server for waiting printing jobs on the NetWare server.

NetWare Server is the name of the NetWare file server that provides printer queues.

## 7.8 AppleTalk Configuration

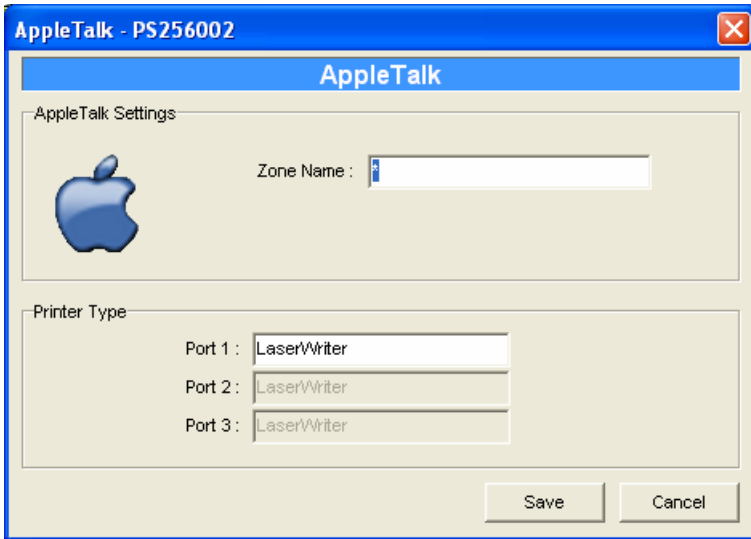

Double Click “AppleTalk” icon and the AppleTalk configuration window will pop-up.

AppleTalk is a data communication protocol often used by Macintoshes. The print server can use these parameters to join the AppleTalk network and share the printer to other AppleTalk workstations. You have to setup the “Zone Name” and “Printer Type” for each printer port of this print server.

Zone Name: Print server has to join zones of AppleTalk before it can be shared to other workstations. Only workstations in the same zone can share the printer. If you want to share the printer to all workstations in all Zones, you should enter only “\*” in the “Zone Name” field.

Printer Type, the type of printer attached to each printer port. You can get the printer type from the manufacturer of the printer.

## 7.9 SNMP Configuration

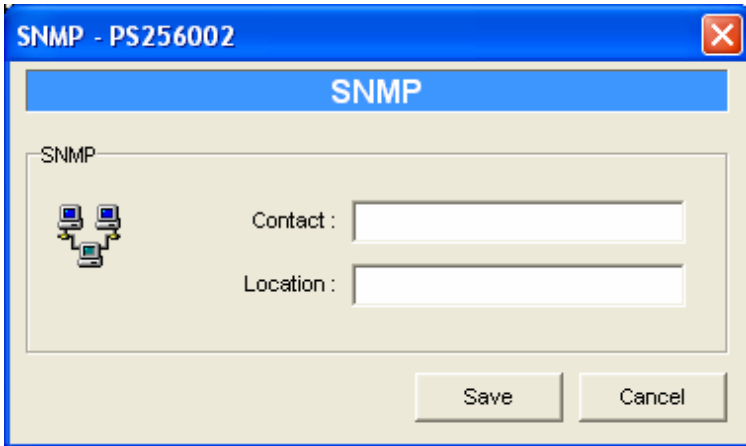

Double Click "SNMP" icon and the SNMP configuration window will pop up.

Contact: You can enter the print server administrator's contact information here. This information will be displayed in the SNMP management tool.

Location: You can enter the installed location of the print server here. This information will be displayed in the SNMP management tool.

## 7.10 SMB Configuration

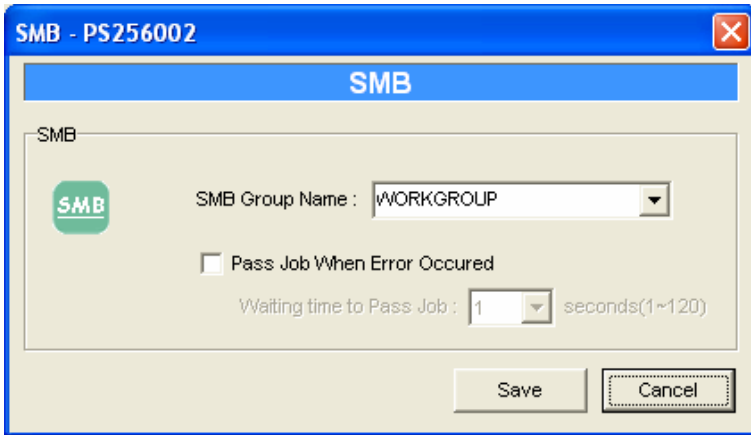

SMB Group Name, the name of SMB group that this print server belongs to. All PC should join the same group before they can use this print server by SMB protocol.

Pass Job when Error Occurred: When the printer is interrupted because of paper out or off line while printing, user can set the interval time to bypass the current printing job. Or the printing document will not be printed completely or with unformatted messages.

## 7.11 System Configuration

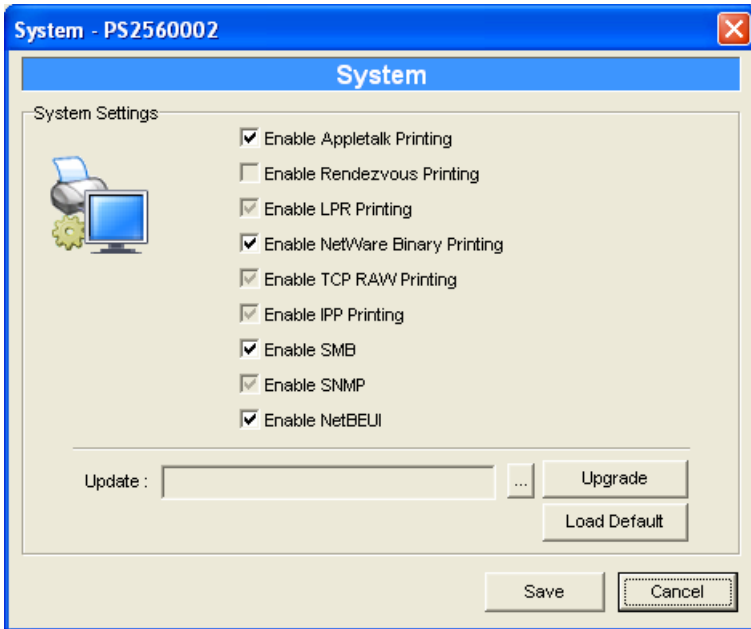

Double Click “System” icon and the System configuration window will pop-up.

In the System configuration page, you can select to enable/disable each printing or management protocol, upgrade the new firmware for this print server, and load factory defaults to the print server.

Upgrade Firmware: You can use this “Upgrade Firmware” tool to update the newest firmware of the print server. Click “...” button and select the correct firmware in your PC. After selecting the firmware file, click the “Upgrade” button to finish the firmware update process.

Load Default: If you want to reset the Print Server to default factory settings, please click “Load Default”.

## 7.12 Wizard

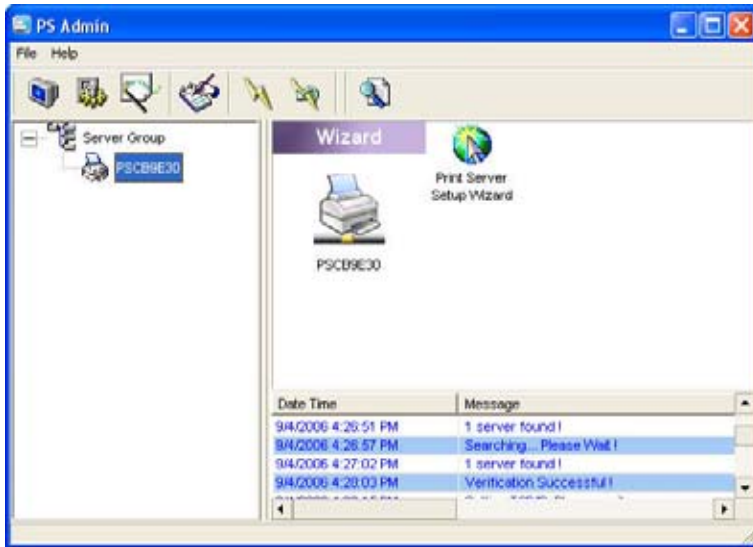

Click “Wizard” icon  on the tool bar, the setup wizard item of the current selected print server will be showed on the right side of the window.

Double click the “Print Server Setup Wizard” the setup wizard will guide you through all the setup process.

Step 1: Set up the name of this print server.

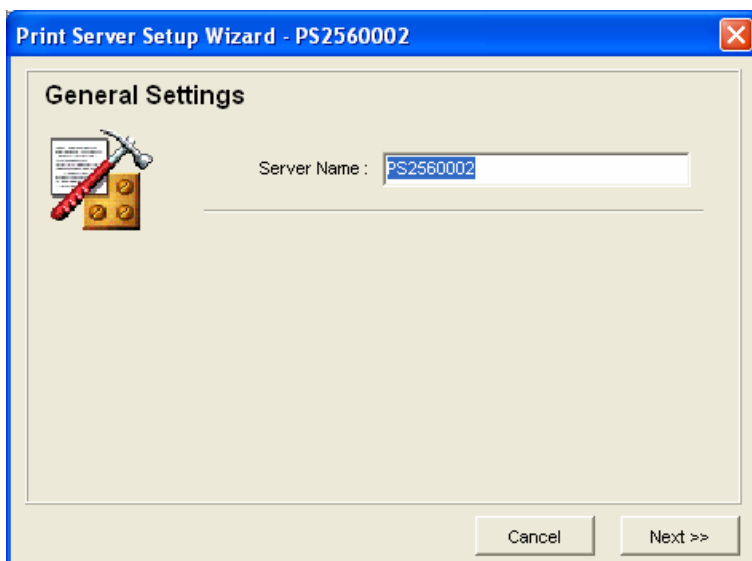

Step 2: Select to enable required printing protocol. Please refer to section 7.11 for detail information.



Step 3: Setup the IP of this print server and the DHCP server. Please refer to section 7.6 for detail information.

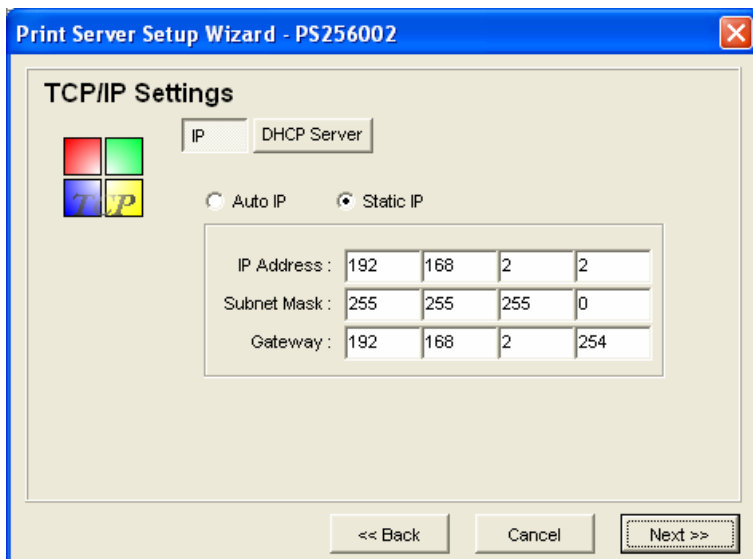

Step 4: Setup the AppleTalk printing. Please refer to section 7.8 for detail information.



Step 5: Setup the NetWare printing. Please refer to section 7.7 for detail information.

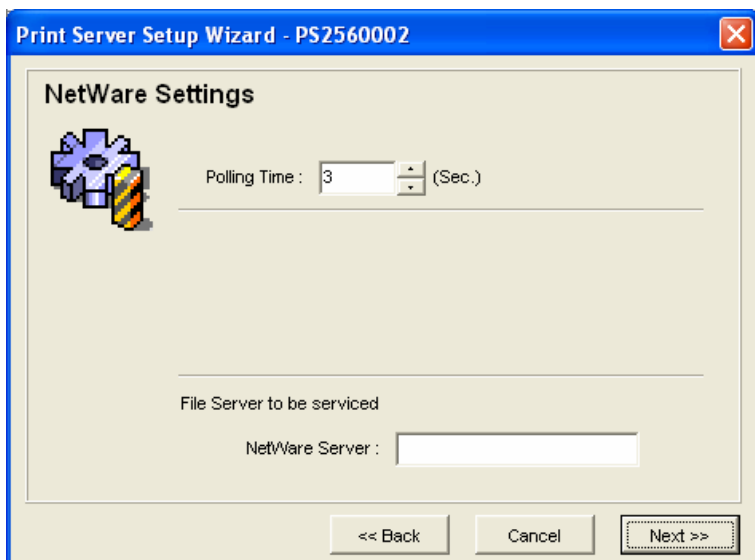

Step 6: Click "Save" to finish setting. Please reboot the print server to let these settings take effect.

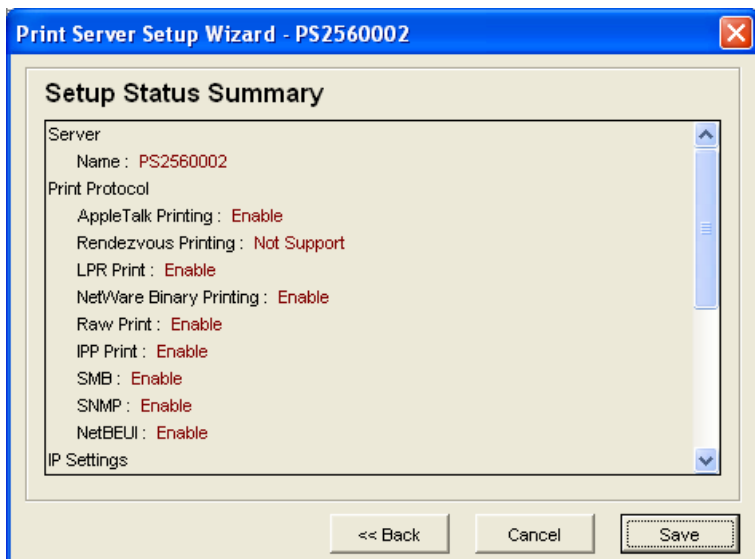



# 8. Web Management

## 8.1 Introduction

Print server can be configured and managed on the Web. Through Local Area Network, or even Internet, administrator can easily configure and manage print server's various main functions in browsers. Simply enter print server's IP address into your browser's address field to manage a print server by print server's built-in Web Server.

The default IP Address, User Name and Password settings of the Print server are as follows.

IP Address: 192.168.2.2

User Name: Admin

Password: 1234

## 8.2 Login

You may use any Web Browser to review the status or configure the settings of the print server. After entering the IP address of the print server, a login page display. You have to enter correct "User Name" and "Password" before going to the Web Management pages.

Notes:

Default User Name is "admin",  
default password is "1234".



## 8.3 Device Status

### 8.3.1 System



The screenshot displays the 'System Information' section of the Micronet SP755D Print Server's configuration interface. The interface has a teal header with the Micronet logo and the device name. Below the header, there are navigation tabs for 'Device Setup', 'Setup Wizard', and 'System Tools'. The main content area is titled 'STATUS SYSTEM' and contains a table of system information.

System Information			
Device Name :	PSCB9E30	Raw Printing :	Enable
Print Server Name :		IPP Printing :	Enable
Model Type :	SP755D Print Server	LPR Printing :	Enable
Firmware Version :	3.0.21	AppleTalk Printing :	Enable
MAC Address :	00:00:B4:CB:9E:30	NetWare Printing :	Enable
USB Port Number :	No	SMB :	Enable
LPT Port Number :	1	SNMP :	Enable
Wireless Lan Status :	No	NetBEUI :	Enable

System Information includes “**Device Name**”, “**Print Server Name**”, “**Model Type**”, “**Firmware Version**”, “**MAC Address**” and the protocols enabled status, etc.

## 8.3.2 Printer



The screenshot shows the Micronet SP755D Print Server web interface. The top header is teal with the Micronet logo and the text "SP755D Print Server". Below the header is a navigation bar with "Device Setup", "Setup Wizard", and "System Tools". A left sidebar contains a menu with "STATUS" (highlighted), "Printer", "SYSTEM", "TCP/IP", "SNMP", "WEB", "RaWare", and "AppleTalk". The main content area has a teal header with the text "This page displays the information of each printer connected to the print server." and a note: "Note: if your printer does not support bi-directional function, some information will not be displayed correctly." Below this is a section titled "Printer 1" with the following information:

Manufacturer :	
Model Number :	
Printing Language Supported :	
Current Status :	Off_line

This page lists information of printer connected to the printer port.

### 8.3.3 TCP/IP

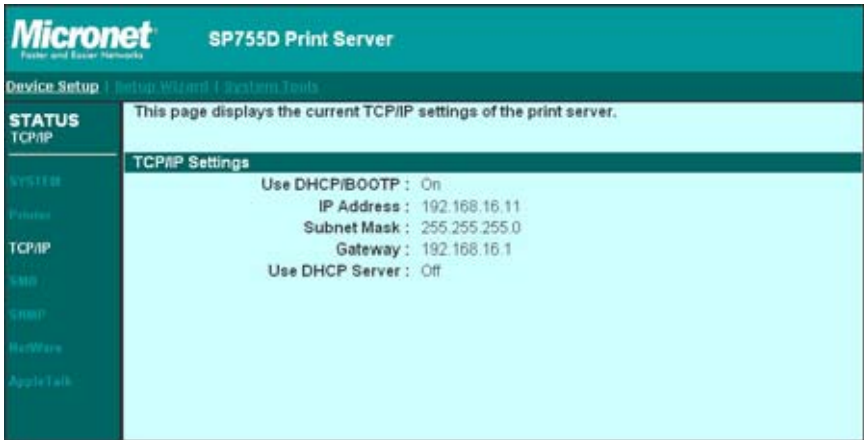

This page lists all TCP/IP settings of the print server including “**IP Address**”, “**Subnet Mask**” and “**Gateway**”. It also lists DHCP server setting.

## 8.3.4 SMB

The screenshot displays the Micronet SP755D Print Server web interface. The top header is teal with the Micronet logo and the device name. Below the header is a navigation bar with 'Device Setup', 'Setup Wizard', and 'System Tools'. A left sidebar contains a menu with 'STATUS' (selected), 'SMB', 'SYSTEM', 'Prints', 'TCP/IP', 'SMB', 'USB', 'NetWare', and 'AppleTalk'. The main content area shows the current SMB settings for the print server.

SMB Settings	
SMB function :	Enable
SMB Group Name :	WORKGROUP
Pass Job When Error Occured :	Disable
Waiting time to pass job :	0 Sec

This page lists the SMB group and the pass job interval time settings of the print server.

## 8.3.5 SNMP

The screenshot shows the web interface for a Micronet SP755D Print Server. The header includes the Micronet logo and the device name. A navigation menu on the left lists various system settings. The main content area displays the current SNMP settings, which are both set to 'None'.

SNMP Settings
SNMP System Contact : None
SNMP System Location : None

This page lists the SNMP settings of the print server. It includes the settings of “**SNMP System Contact**” and “**SNMP System Location**”.

### 8.3.6 NetWare

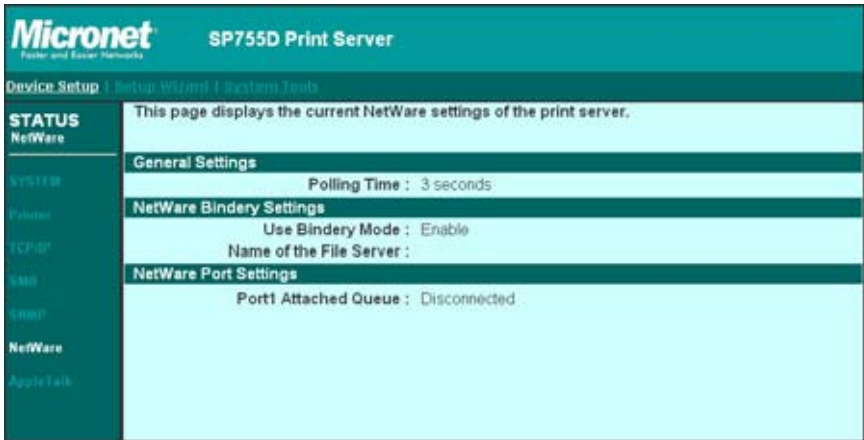

This page lists NetWare settings, including “**Polling Time**”, “**Use Bindery Mode**”, “**Name of the File Server**” and “**Port Attached Queue**”.

## 8.3.7 AppleTalk

The screenshot shows the configuration interface for a Micronet SP755D Print Server. The page title is "Micronet SP755D Print Server" with the tagline "Faster and Easier Networks". The navigation bar includes "Device Setup", "Setup Wizard", and "System Tools". A left sidebar lists various configuration categories: STATUS, AppleTalk, SYSTEM, Printing, TCP/IP, SMB, SNMP, NetWare, and AppleTalk (highlighted). The main content area displays the current AppleTalk settings for the print server. It includes a header "AppleTalk Settings" and a table with the following information:

Printer 1
Printer Type : LaserWriter

This page lists AppleTalk settings, including “**AppleTalk Zone Name**” and “**Printer Type**” of the printer connected to the print port.

## 8.4 Setup Wizard

### 8.4.1 System



The screenshot shows the Micronet SP755D Print Server Setup Wizard. The top header is teal with the Micronet logo and the text "SP755D Print Server". Below the header, there are navigation links: "Previous Steps", "Setup Wizard", and "Return To Help". The main content area is light blue and contains the following text: "This Menu allows you to configure general system settings of the Print Server." and "Click 'Save and Next' to continue." Below this, there is a section titled "System Settings" with three input fields: "Print server Name :", "Password :", and "Re-type Password :". The password fields are masked with four asterisks. A "SAVE & NEXT" button is located at the bottom right of the form. On the left side, there is a dark teal sidebar with the following menu items: "SETUP SYSTEM", "SYSTEM", "TCP/IP", "USB", "SMB", "NetWare", "AppleTalk", and "Misc. Settings".

You can change the print server name and password of the print server from here.

**Print Server Name**, the name of the print server. You can use this name to identify the print server when you are searching for the print server by the administration and client utilities.

**Password**, enter the password you want to change to the print server. The password can be up to 7-digit alphanumeric format. The default password is "1234".

**Re-type Password**, enter the password you want to change to the print server again.

## 8.4.1.1 Advanced Settings



You can enable/disable the printing protocols from the screen. To enable the function, please select “**Enable**”; to disable the function, please select “**Disable**”.

## 8.4.2 TCP/IP



You can configure the print server to automatically get IP from DHCP server or manually specify static IP. The print server also has a built-in DHCP server. You can enable this DHCP server and let it manages IP for you.

If you need the print server to automatically get an IP from DHCP server, select **“Enable Obtain TCP/IP Settings Automatically (Use DHCP/BOOTP)”**. You also can select **“Disable Use the following TCP/IP Settings”** to manually assign **“IP Address”**, **“Subnet Mask”** and **“Gateway”** for the print server.

You can enable/disable or set auto for the print server’s DHCP server. The DHCP server is disabled by default. If the DHCP Server is enabled or set Auto, you have to assign a range of IP addresses here. Fill in the **“Start IP”**, **“Range”**, **“DNS”**, **“Subnet Mask”** and **“Gateway”**, and the print server will assign a unique IP for each client. Note that when **“Auto”** is selected, the DHCP Server of the print server will be enabled only when there is no other DHCP Server within the network.

## 8.4.3 SMB



You can enable/disable the SMB protocol from here. If SMB is enabled, enter the **"SMB Group Name"** to specify the SMB group that this print server belongs to. All PC should join the same group before they can use this print server by SMB protocol.

**"Pass Job When Error Occured"** is for you to set the interval time for bypassing the current printing job in order to avoid the printing job is not printed completely while the printer is interrupted unexpectedly because of paper out or off line.

## 8.4.4 SNMP



The print server supports SNMP configuration. If it is enabled, please set up the following parameters.

**SNMP System Contact:** You can enter the print server administrator's contact information here. This information will be displayed in the SNMP management tool.

**SNMP System Location:** You can enter the installed location of the print server here. This information will be displayed in the SNMP management tool.

## 8.4.5 NetWare

The screenshot shows the Micronet SP755D Print Server Setup Wizard. The interface is divided into a left sidebar and a main content area. The sidebar contains the following menu items: SETUP, NetWare, SYSTEM, TCP/IP, SMB, LPR, NetWare, AppleTalk, and Save Settings. The main content area has a teal header with the Micronet logo and the text 'SP755D Print Server'. Below the header, there are navigation links: 'Back to Setup', 'Setup Wizard', and 'Restart Tools'. The main content area is titled 'NetWare' and contains the following text: 'This Menu allows you to configure the NetWare function of the Print Server.' and 'Click "Save and Next" to continue.' Below this, there is a section titled 'General Settings' with a 'Polling Time' field set to '3' seconds (min: 3, max: 29 seconds). Underneath is a section titled 'NetWare Bindery Settings' with a 'Name of the File Server' field. At the bottom of the main content area is a 'SAVE & NEXT' button.

This print server supports NetWare Bindery Printing method. The print server periodically polls the NetWare server printer queues for printing jobs. You have to assign the NetWare server name, print server polling interval and the name of queue on the NetWare server for each printer port.

Polling Time is the polling interval of the print server for waiting printing jobs on the NetWare server.

Name of the File Server is the name of the NetWare file server that provides printer queues.

## 8.4.6 AppleTalk



AppleTalk is a data communication protocol often used by Macintoshes. The print server can use these parameters to join the AppleTalk network and share the printer to other AppleTalk workstations. You have to select to enable or disable AppleTalk, and setup the “**Zone Name**” and “**Printer Type**” for each printer port of this print server.

**AppleTalk Enable:** Enable or disable “**AppleTalk**”.

AppleTalk Zone Name: Print server has to join zones of AppleTalk before it can be shared to other workstations. Only workstations in the same zone can share the printer. If you want to share the printer to all workstations in all Zones, you should enter only “\*” in the “Zone Name” field.

Printer Type, the type of printer attached to each printer port. You can get the printer type from the manufacturer of the printer.

## 8.4.7 Save Settings

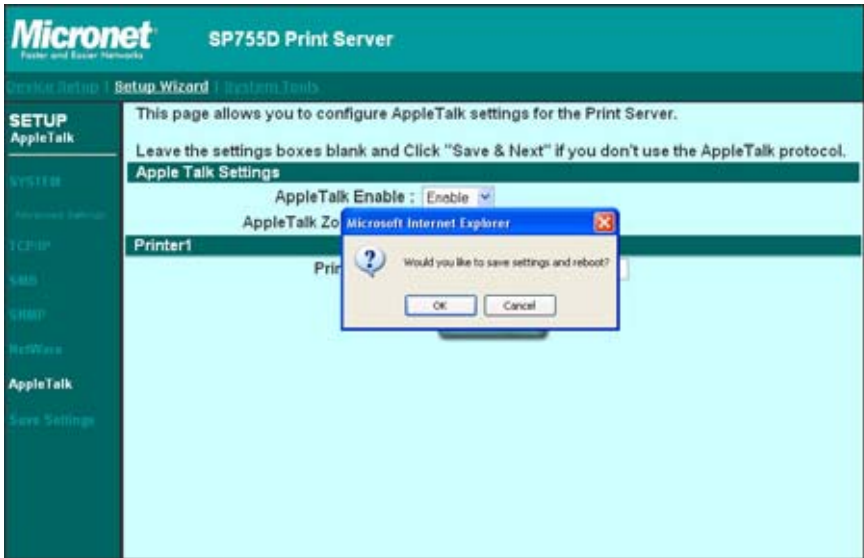

You can click the **"Save Settings"** to save the settings and restart the system.

## 8.5 System Tools

### 8.5.1 Load Default



You can use this page to restore the factory default settings. All of your previous setup will be cleared.

## 8.5.2 Upgrade Firmware from Browser



You can upgrade new firmware for this print server in this page. Click **“Browse”** to select the new firmware in your storage and then click **“OK”**, the firmware will be updated in several minutes.

Be aware that if you have started upgrading firmware, you have to follow all the upgrading steps or the print server can't turn back to normal configuration.

# 9. IPP Printing

## 9.1 Introduction

IPP (Internet Printing Protocol) Printing provides a convenient way of remote printing service by TCP/IP. The print server can support IPP printing by default. It is needless to do any setting. Any PC that can support IPP printing, for example Windows 2000/XP, can directly use the print server by IP. By using the IPP printing, you can share the printer to all the PCs that can access the print server by IP. You can even share your printer to Internet users.

## 9.2 System Setup

### 9.2.1 Print Server Side

It is needless to do any setting on the print server side. Make sure the print server has correct IP settings. If you want to share the printers to Internet users, you have to set a real IP to the print server. You also have to make sure that any gateway, router or firewall does not block IPP protocol if you have these gateway devices installed in your network.

### 9.2.2 Client Side

You only need to perform Window's standard Add New Printer procedure.

Step1. Click "**Start**", choose "**Settings**" and select "**Printers and Faxes**".

Step2. Click "**Add a Printer**".

Step3. The "**Add Printer Wizard**" is displayed. Click "**Next**".

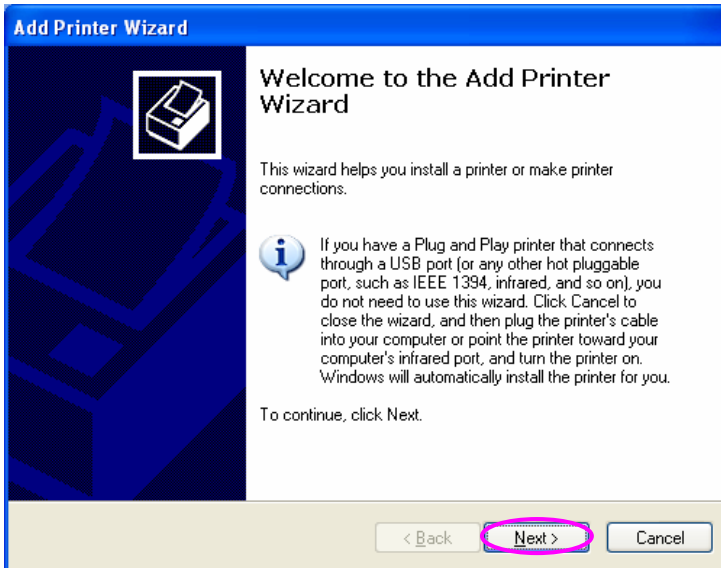

Step4. Select “**A network printer, or a printer attached to another computer**”. Click “**Next**”.

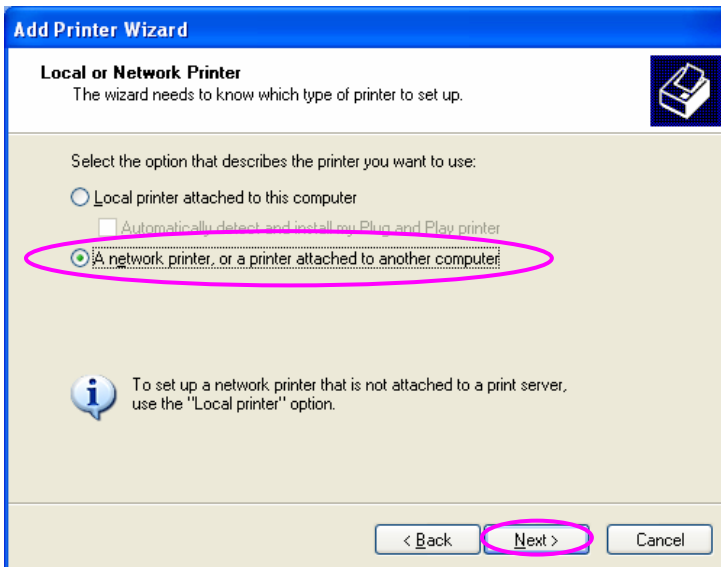

Step5. Select **“Connect to a printer on the Internet or on a home or office network”** and enter the URL of print server. The URL format is **“http://IP:631/Port Name”**. The IP should be the print server’s IP. The number 631 is IPP standard port number. Port Name is the port name of print server that your printer is connected to. The default port name is **“lpt1”**. One example of the URL is `http://192.168.3.66:631/lpt1`. After entering the URL of print server, click **“Next”**.

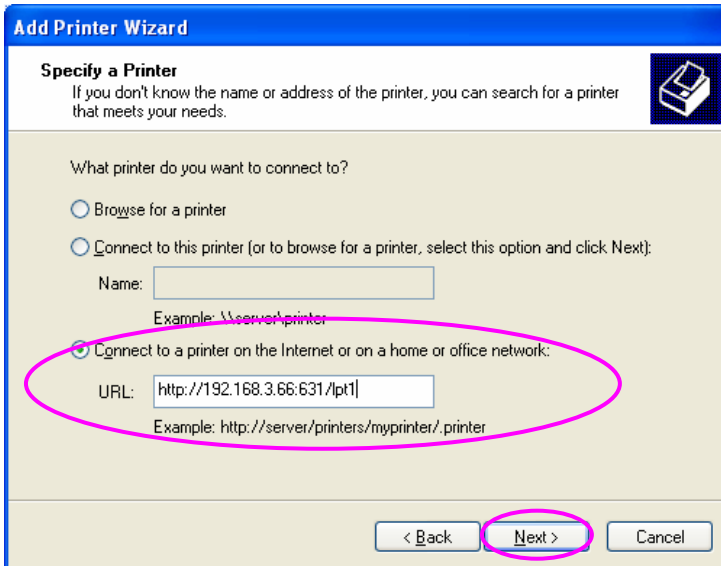

Step6. Select a suitable printer manufacturer and the printer model and click **“Next”**. If your printer is not in the list, click **“Have Disk...”** to install the driver of the printer. After installation, the printer model will be added to the list.

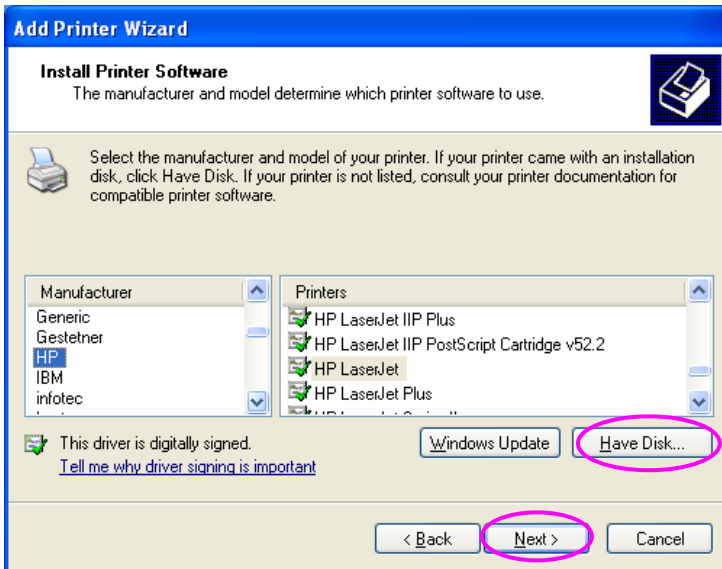

Step7. Choose to set the print whether as a default printer or not. Click “Next”.

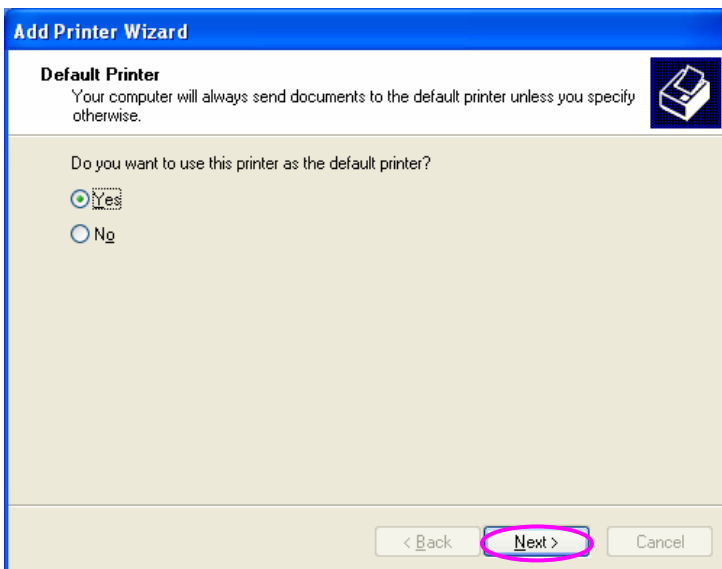

Step8. You have added the network printer to the PC successfully. The information of the printer is displayed in the windows. Click **“Finish”**.

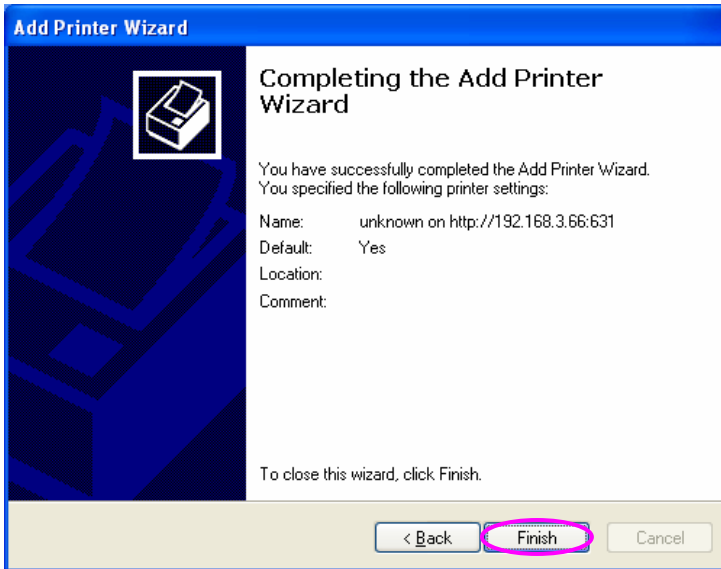

# 10. Windows XP SP2 Setup

In Windows XP SP2, XP SP2's firewall would block the unknown communications. This print server has allowed the communications data passed through the XP SP2's firewall.

In case that you do not find any print server listed on the “**Available Ports**” in “**Network Ports Quick Setup**”, please follow the steps below.

Step1. Click “**Start**”, choose “**Settings**” and select “**Network Connections**”.

Step2. Right click “**Local Area Connection**” and select “**Properties**”.

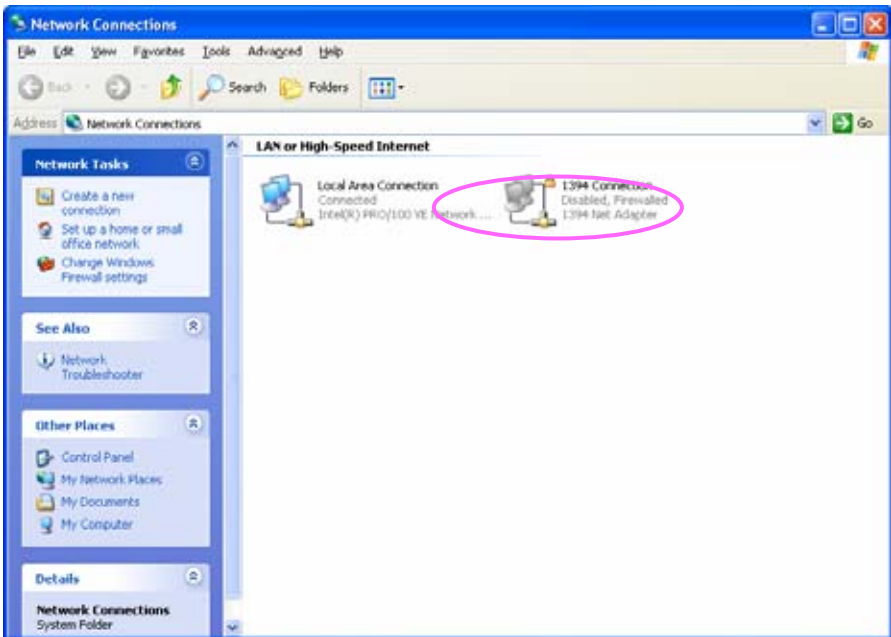

Step3. Select “**Advanced**” tab and click “**Settings...**”.

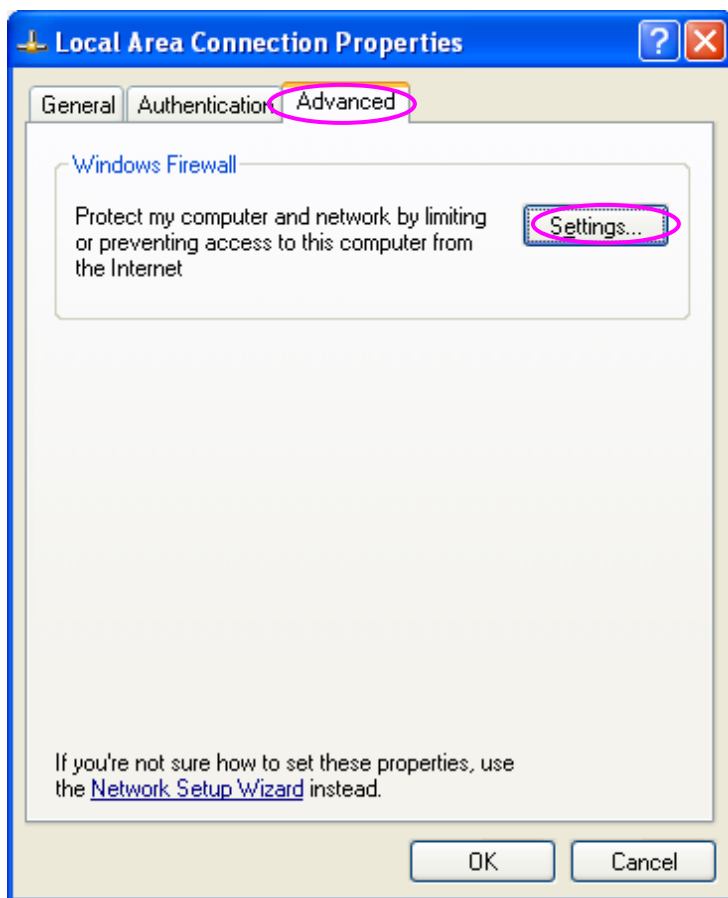

Step4. Select “**Exceptions**” tab and click “**Add Program...**”.

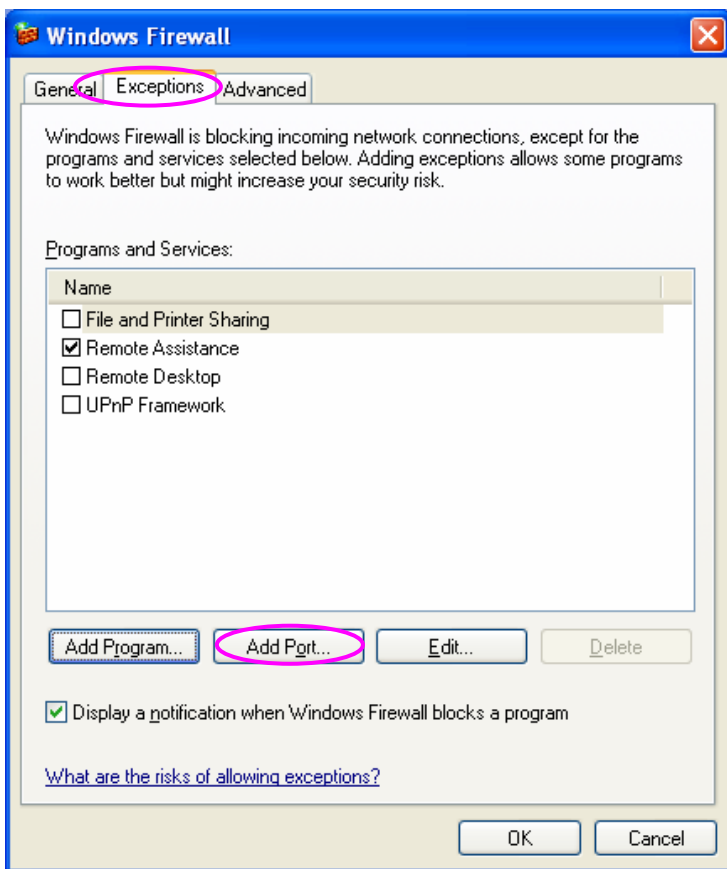

Step5. Click "**Browse**" to add a new program.

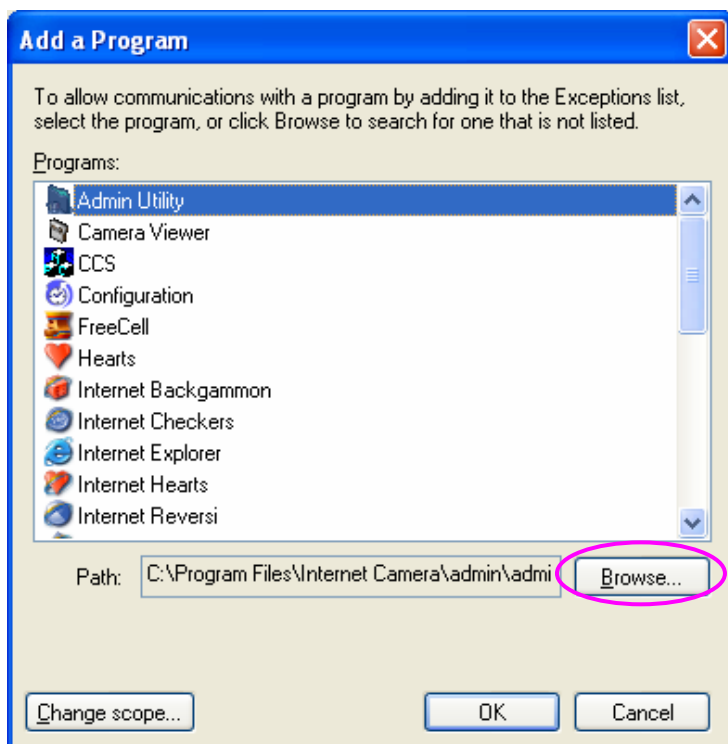

Step6. Open the “**NPUtil**” file from “**C:\Program Files\PrintServer Utilities**” (where C:\ is the system drive).

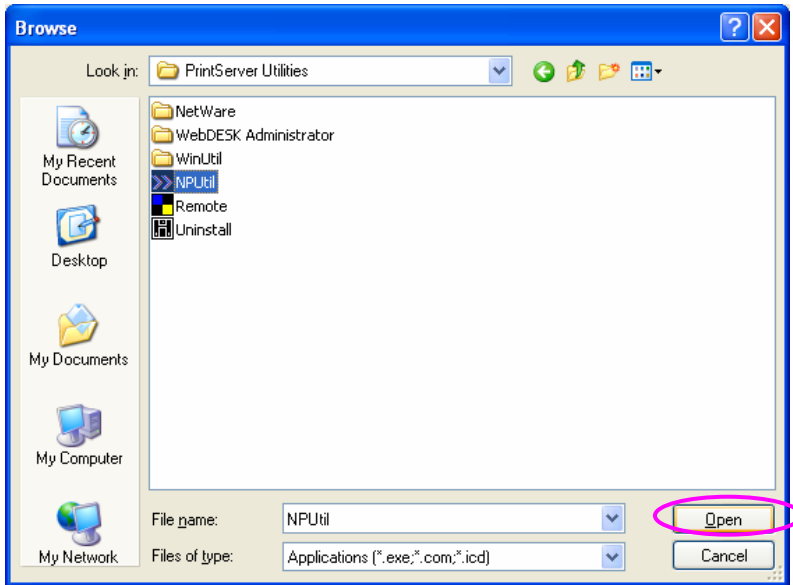

Step7. A new program “**Network Ports Quick Setup**” is displayed in the list, click “**OK**”.

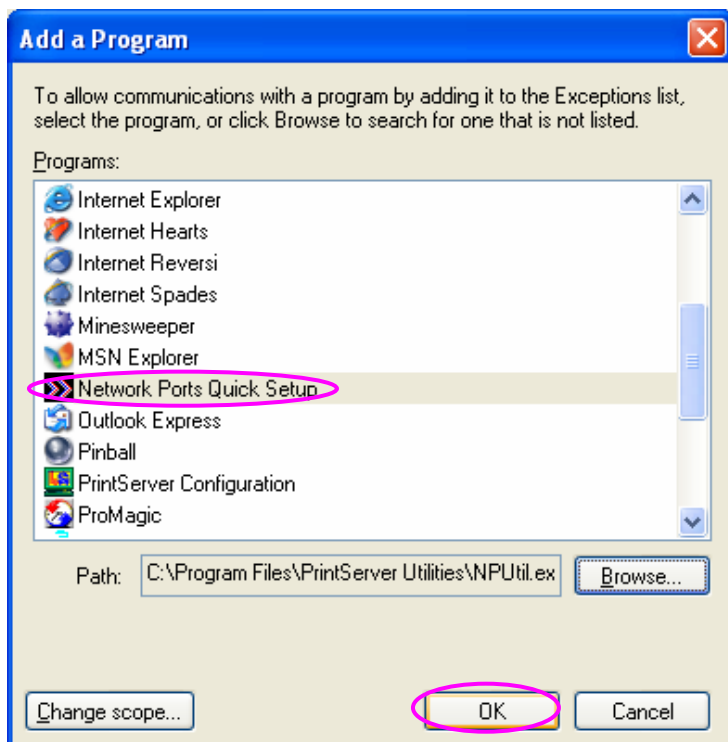

Step8. Click “OK”. You have completed the setting. The Windows XP SP2 will allow the incoming network connections activated by the program.

